

TORSIONALLY RIGID ALL-STEEL COUPLINGS N-ARPEX AND ARPEX SERIES



Series N-ARPEX ARN-6/-8/-10	6/3
General	6/3
Benefits	6/3
Application	6/4
Design and configurations	6/5
Technical specifications	6/8
Available standard dimensions for the shaft spacing S	6/10
Type NEN/NHN	6/12
TYPE MCECM/MCHCM	6/14
TYPE MFEFM/MFHFM	6/16
TYPE BEB	6/18
Further hubs	6/19
Spare and wear parts	6/22
Length-dependent specifications	6/23
Other design options	6/27

Series ARPEX ARW-4/-6	6/28
General	6/28
Benefits	6/28
Application	6/28
Design and configurations	6/29
Technical specifications	6/30
Type NHN	6/32
Spare and wear parts	6/34

Series ARPEX ARF-6	6/35
General	6/35
Benefits	6/35
Application	6/35
Design and configurations	6/36
Technical specifications	6/37
Types GG and GJ	6/38
Spare and wear parts	6/40



N-ARPEX
FLENDER

GENERAL



Coupling suitable for use in potentially explosive atmospheres.

Complies with the current ATEX Directive for:

CE  II 2G Ex h IIC T6 ... T2 Gb X

 II 2D Ex h IIIC T85 °C ... 250 °C Db X

 I M2 Ex h Mb X

Benefits

N-ARPEX couplings of the ARN-6/-8/-10 series are outstanding for their application-optimized construction. The NEN, BEB, MCECM, MFEFM series meet the requirement of **API 610**. Coupling type in accordance with **API 671** is also possible. For speeds of over 1,800 rpm the five-part version with pre-assembled intermediate unit is used.

A special catching device acts to secure the intermediate spacer in the event of plate breakage. Application of the N-ARPEX couplings in potentially explosive atmospheres in accordance with the current ATEX Directive is permitted.

GENERAL

Application

N-ARPEX couplings of the ARN-6/-8/-10 series are used wherever reliable torque transmission is called for, even in cases of often unavoidable shaft misalignment. They are universally applicable over a temperature range of from -50 °C (or even as low as -60 °C on request) up to +280 °C, are torsionally rigid, free of torsional backlash and enable quiet running at a constant angular velocity. They are wear-free and maintenance-free and, if correctly fitted, can be expected to have an unlimited service life.

Especial consideration is given to use in pump and compressor drives. Available for this are couplings with standardised intermediate spacer lengths from stock (see following tables).

By the launch of the new FLENDER N-ARPEX all-steel multiple-disk couplings Flender is continuing the success story of the proven ARPEX coupling series.

An optimised plate pack and a reworked component part design enable even higher torques and speeds to be transmitted.

In short, the new design of the plate packs, the closed flange geometry, the standard catching device of the intermediate spacer and FEM-optimised force distribution inside the all-steel multiple-disk coupling clearly show that the development has paid off.

Main areas of application for the ARN-6/-8/-10 series:

- Pumps
- Fans
- Compressors
- Generator and turbine drives
- Axial and radial blowers
- Paper-making machines and printing machines
- Mixers, Stirrers
- Extruders
- Lifting and traversing gears
- Marine drive
- Water screw drives



Design and configurations

NEN

The design of an N-ARPEX type NEN is shown in the following illustration. The coupling comprises two hubs, an intermediate spacer and two plate packs that in the ARN-6 series are bolted together alternately with close-fitting bolts and in the ARN-8/10 series by means of a Flender conical screw connection. The coupling is available in fixed lengths from stock. Other spacer lengths are manufactured to order. Hubs are designed with threaded pull-off holes.

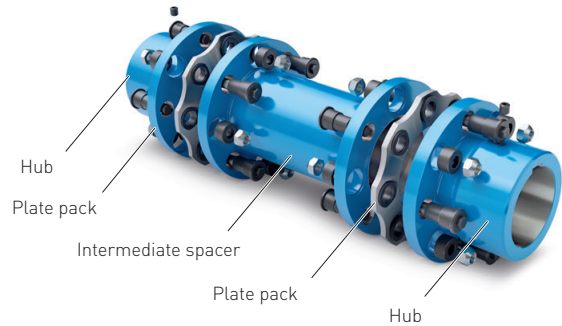

MCECM

The design of an N-ARPEX type MCECM is shown in the following illustration. The coupling comprises two hubs and a pre-assembled intermediate unit (CEC), where the plate packs are bolted together with an intermediate spacer and intermediate flanges at the factory. All that need be done at the construction site is to bolt the hubs with the intermediate flanges. The coupling is available in fixed lengths from stock. Other spacer lengths are manufactured to order. Hubs are designed with threaded pull-off holes.

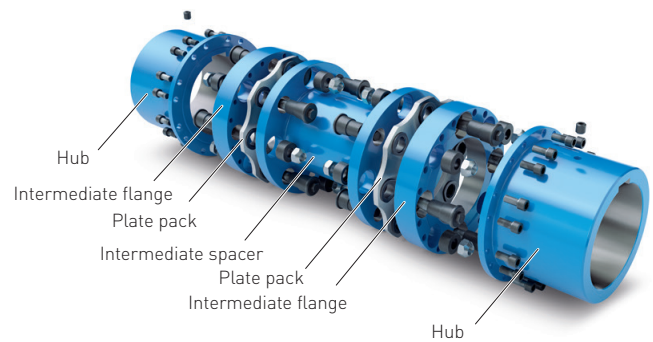

MFEFM

The following illustration shows the N-ARPEX type MFEFM. It most differs from the type MCECM by the considerably increased bore capacity, for which reason this type is intended precisely for comparatively large shaft diameters. The coupling is available in fixed lengths from stock. Other spacer lengths are manufactured to order. Hubs are designed with threaded pull-off holes.

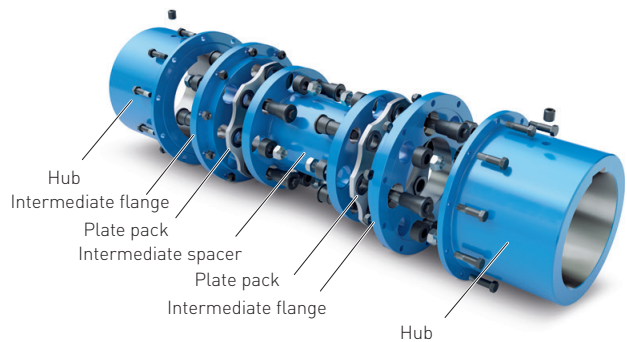

GENERAL

Variants of the N-ARPEX coupling, ARN-6/-8/-10 series

Type	Series			Description
	ARN-6	ARN-8	ARN-10	
NEN	■	■	■	Variant with intermediate spacer machined on all sides, length variable
BEB	■	-	-	Variant with intermediate spacer machined on all sides
MCECM	■	■	-	Variant with preassembled intermediate unit and intermediate spacer machined on all sides, length variable
MFEFM	■	■	■	
NHN	■	■	■	Version with variable spacer tube – specially for greater shaft distances (up to 6,500 mm)
MCHCM	■	■	-	Version with pre-assembled intermediate unit and with variable spacer tube – specially for greater shaft distances (up to 6,500 mm)
MFHFM	■	■	■	

The coupling parts of the N-ARPEX ARN-6/-8/-10 series with the exception of the H spacers have been machined on all sides. The H spacers are delivered with unmachined, primed spacer tube.

Dimension sheets and 3D models of the standard types as well as application-related coupling types are available from the DTK selection module at [flender.com](https://www.flender.com).

Plate-pack designs

The plate packs of the N-ARPEX ARN series are designed with hexagon, octagon and decagon plates, depending on the coupling size. The number of screw connections is indicated in the denomination of the ARN-6/-8/-10 series. Hexagon plates have 6 bolting points, octagon plates have 8 bolting points and decagon plates have 10 bolting points.

The hexagon plates, octagon plates and decagon plates up to size 631 are designed as ring plates. Sizes 694 to 988 are designed as segmented plates.

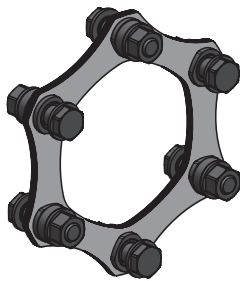

Size 86-6 to 343-6
(hexagon plates)

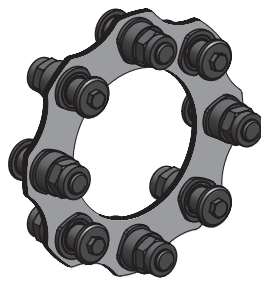

Size 219-8 to 631-8
(octagon plates)

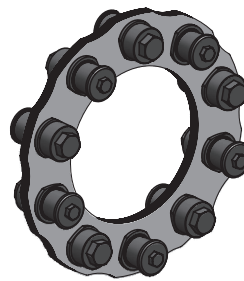

Size 495-10 to 631-10
(decagon plates)

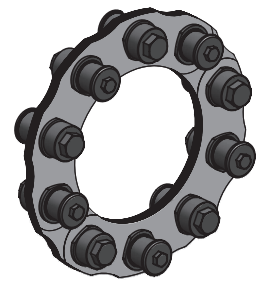

Size 694-10 to 988-10
(decagon plates/segment)

Plate pack screw connection

In the ARN-6 series the plate pack screw connection on N-ARPEX couplings is designed in the form of a close-fitting screw connection. In the ARN-8 and ARN-10 series a conical bolt connection by Flender is used.

The advantage of this screw connection is the considerably simplified installation in the case of large screw connections.

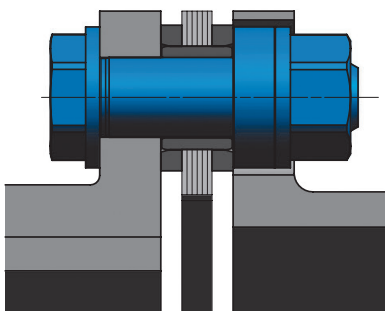

Screw connection / ARN-6 series
Size 86-6 – 343-6

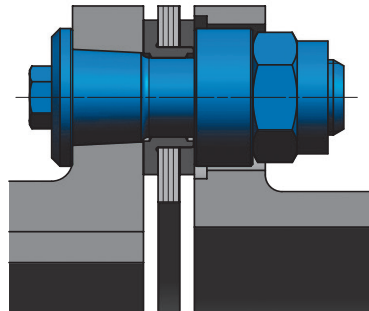

Screw connection / ARN-8 series
Size 219-8 to 354-8

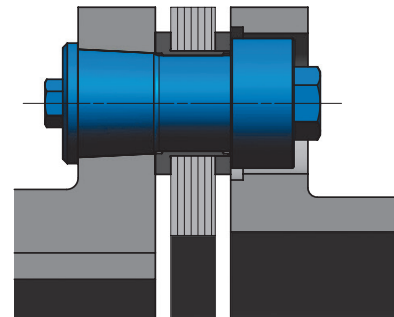

Screw connection / ARN-8 /-10 series
Size 387-8 to 631-8 / Size 495-10 to 988-10

GENERAL

Technical specifications

Power ratings, NEN/NHN, BEB, MCECM/MCHCM and MFEFM/MFHFM series														
Size DA mm	Type	Rated torque T_{KN} kNm	Maximum torque T_{Kmax} kNm	Overload torque T_{KOL} kNm	Fatigue torque				Maximum speed n_{Kmax} rpm	Maximum permitted shaft misalignment (The permissible radial misalignment ΔK_r depends on the total length of the coupling) $\pm \Delta K_a$ $\pm \Delta K_w$		Torsional stiffness for a plate pack C_{Tdyn} MNm/rad		
					T_{KW0} $T_N = 0\%T_{KN}$ kNm	$T_{KW} = T_{KW0} \cdot (1 - T_N/T_{KN})$ 25% T_{KN} kNm	50% T_{KN} kNm	75% T_{KN} kNm		mm				
86-6	6-Bolt	0.35	0.7	0.875	0.175	0.131	0.088	0.044	24000	1.2	1.0 °	0.132		
103-6		0.5	1	1.25	0.25	0.188	0.125	0.063	20000	1.4		0.206		
122-6		0.95	1.9	2.375	0.475	0.356	0.238	0.119	17000	2		0.463		
133-6		1.25	2.5	3.125	0.625	0.469	0.313	0.156	15000	2.2		0.608		
159-6		2.1	4.2	5.25	1.05	0.788	0.525	0.263	13000	2.6		0.986		
174-6		2.5	5	6.25	1.3	0.975	0.65	0.325	12000	3		1.19		
184-6		3.8	7.6	9.5	1.9	1.425	0.95	0.475	11000	3.2		1.83		
203-6		5	10	12.5	2.5	1.875	1.25	0.625	10000	3.4		2.59		
217-6		6.2	12.4	15.5	3.1	2.325	1.55	0.775	9500	3.4		3.28		
251-6		10.5	21	26.25	5.5	4.125	2.75	1.375	8000	4.1		4.71		
268-6		13.8	27.6	34.5	6.9	5.175	3.45	1.725	7500	4.2		5.63		
291-6		18.2	36.4	45.5	9.1	6.825	4.55	2.275	7000	4.6		8.27		
318-6		23	46	57.5	11.5	8.625	5.75	2.875	6500	5		10.94		
343-6		28	56	70	14	10.5	7	3.5	6000	5.3		12.15		
219-8		8-Bolt	10	20	25	5	3.75	2.5	1.25	9500		1.7	0.4 °	6.31
241-8			15	30	37	7.5	5.625	3.75	1.875	8700		1.9		7.64
262-8	20		40	50	10	7.5	5	2.5	8000	2.1	9.09			
285-8	27		54	67	13.5	10.125	6.75	3.375	7300	2.2	11.9			
302-8	35		70	87	17.5	13.125	8.75	4.375	6900	2.4	16.2			
321-8	43		86	107	21.5	16.125	10.75	5.375	6500	2.5	21.9			
354-8	56		112	140	28	21	14	7	5900	3	29.1			
387-8	72		144	180	36	27	18	9	5400	3.3	40			
411-8	93		186	232	46.5	34.875	23.25	11.625	5100	3.4	46.9			
447-8	122		244	305	61	45.75	30.5	15.25	4600	2.5	60.3			
495-8	160		320	400	80	60	40	20	4200	3	76.9			
546-8	212		424	530	106	79.5	53	26.5	3800	3.4	100			
587-8	270		540	675	135	101.25	67.5	33.75	3500	3.6	116			
631-8	350		700	875	175	131.25	87.5	43.75	3300	3.8	138			
495-10	10-Bolt		200	350	450	80	60	40	20	4200	2	0.3 °		150
546-10			270	473	608	108	81	54	27	3800	2.3			194
587-10		352	616	792	140.8	105.6	70.4	35.2	3500	2.4	236			
631-10		450	788	1013	180	135	90	45	3300	2.5	274			
694-10		630	1103	1418	252	189	126	63	3000	2.7	405			
734-10		760	1330	1710	304	228	152	76	2800	2.8	501			
790-10		950	1663	2138	380	285	190	95	2600	3	632			
887-10		1400	2450	3150	560	420	280	140	2300	3.5	858			
988-10		2000	3500	4500	800	600	400	200	2100	3.9	1163			

Notes

- The permitted shaft misalignments ΔK_a , ΔK_r and ΔK_w are maximum values and must not occur at the same time (see table on page 6/9).
- The maximum permissible radial misalignment depends on the shaft distance S. It can be determined for the stated types by using the following formulas:
 NEN/NHN: $\Delta K_r = (S - S1) \cdot \tan(\Delta K_w)$
 BEB, MCECM/ MCHCM and MFEFM/ MFHFM: $\Delta K_r = (LZ + S1) \cdot \tan(\Delta K_w)$
- T_{Kmax} is permitted five times per hour.
- Length-related values like torsional stiffness, total weight and mass moment of inertia are listed in the tables on pages 6/23 to 6/25.
- The torsional stiffness of the plate packs relates to the nominal range of the coupling. For determination of torsional stiffness for a specific operating point outside the nominal range Flender must be consulted.

Permitted shaft misalignments, types NEN/NHN, BEB, MCECM/MCHCM and MFEFM/MFHFM

The permitted shaft misalignments ΔK_a , ΔK_r and ΔK_w are maximum values and must not occur at the same time. The specified axial misalignments apply to the complete coupling. The permissible angular misalignments have been specified per coupling joint. As all N-ARPEX types are designed to be double-jointed, there is a direct interrelation between radial and angular misalignment.

NEN/NHN: $\Delta K_r = (S - S1) \cdot \tan(\Delta K_w)$
 BEB, MCECM/MCHCM and MFEFM/MFHFM: $\Delta K_r = (LZ + S1) \cdot \tan(\Delta K_w)$

To determine the permissible misalignment, values must, if necessary, be converted.

Size DA	Permitted angular misalignment $\pm \Delta K_w$										
	0.0°	0.1°	0.2°	0.3°	0.4°	0.5°	0.6°	0.7°	0.8°	0.9°	1.0°
	Permitted axial misalignment $\pm \Delta K_a$ in mm										
86-6	1.2	1.1	1	0.8	0.7	0.6	0.5	0.4	0.2	0.1	0
103-6	1.4	1.3	1.1	1	0.8	0.7	0.6	0.4	0.3	0.1	0
122-6	2	1.8	1.6	1.4	1.2	1	0.8	0.6	0.4	0.2	0
133-6	2.2	2	1.8	1.5	1.3	1.1	0.9	0.7	0.4	0.2	0
159-6	2.6	2.3	2.1	1.8	1.6	1.3	1	0.8	0.5	0.3	0
174-6	3	2.7	2.4	2.1	1.8	1.5	1.2	0.9	0.6	0.3	0
184-6	3.2	2.9	2.6	2.2	1.9	1.6	1.3	1	0.6	0.3	0
203-6	3.4	3.1	2.7	2.4	2	1.7	1.4	1	0.7	0.3	0
217-6	3.4	3.1	2.7	2.4	2	1.7	1.4	1	0.7	0.3	0
251-6	4.1	3.7	3.3	2.9	2.5	2.1	1.6	1.2	0.8	0.4	0
268-6	4.2	3.8	3.4	2.9	2.5	2.1	1.7	1.3	0.8	0.4	0
291-6	4.6	4.1	3.7	3.2	2.8	2.3	1.8	1.4	0.9	0.5	0
318-6	5	4.5	4	3.5	3	2.5	2	1.5	1	0.5	0
343-6	5.3	4.8	4.2	3.7	3.2	2.7	2.1	1.6	1.1	0.5	0
219-8	1.7	1.28	0.85	0.43	0	-	-	-	-	-	-
241-8	1.9	1.43	0.95	0.48	0	-	-	-	-	-	-
262-8	2.1	1.58	1.05	0.53	0	-	-	-	-	-	-
285-8	2.2	1.65	1.1	0.55	0	-	-	-	-	-	-
302-8	2.4	1.8	1.2	0.6	0	-	-	-	-	-	-
321-8	2.5	1.88	1.25	0.63	0	-	-	-	-	-	-
354-8	3	2.25	1.5	0.75	0	-	-	-	-	-	-
387-8	3.3	2.48	1.65	0.83	0	-	-	-	-	-	-
411-8	3.4	2.55	1.7	0.85	0	-	-	-	-	-	-
447-8	2.5	1.88	1.25	0.63	0	-	-	-	-	-	-
495-8	3	2.25	1.5	0.75	0	-	-	-	-	-	-
546-8	3.4	2.55	1.7	0.85	0	-	-	-	-	-	-
587-8	3.6	2.7	1.8	0.9	0	-	-	-	-	-	-
631-8	3.8	2.85	1.9	0.95	0	-	-	-	-	-	-
495-10	2	1.33	0.67	0	-	-	-	-	-	-	-
546-10	2.3	1.53	0.77	0	-	-	-	-	-	-	-
587-10	2.4	1.6	0.8	0	-	-	-	-	-	-	-
631-10	2.5	1.67	0.83	0	-	-	-	-	-	-	-
694-10	2.7	1.35	0	-	-	-	-	-	-	-	-
734-10	2.8	1.4	0	-	-	-	-	-	-	-	-
790-10	3	1.5	0	-	-	-	-	-	-	-	-
887-10	3.5	1.75	0	-	-	-	-	-	-	-	-
988-10	3.9	1.95	0	-	-	-	-	-	-	-	-

GENERAL

Available standard dimensions for the shaft spacing S

6

Type NEN/NHN														
Size DA mm	Shaft distance S		Preferred dimension V NEN											
	NEN min. mm	NHN min. mm		100	140	180	200	250	300	{88.9} 3.5"	{127} 5"	{177.8} 7"	{228.6} 9"	-
86-6	60	300	100	■										
103-6	60	300	100	■										
122-6	71	300	100	■										
133-6	73	300	100	■										
159-6	91	300	100	■										
174-6	92	300	100	■										
184-6	119	350	140		■									
203-6	120	350	140		■									
217-6	123	350	140		■									
251-6	149	350	180			■								
268-6	175	350	180			■								
291-6	177	350	180			■								
318-6	189	400	200				■							
343-6	190	400	200				■							
219-8	129	350	140		■									
241-8	135	350	140		■									
262-8	145	350	180			■								
285-8	162	350	180			■								
302-8	179	350	180			■								
321-8	196	400	200				■							
354-8	214	400	250					■						
387-8	246	400	250					■						
411-8	256	400	300						■					
447-8	270	400	300						■					
495-8	281	600	300						■					
546-8	299	600	300						■					
587-8	315	600	320											■
631-8	334	600	340											■
495-10	281	600	300						■					
546-10	299	600	300						■					
587-10	315	600	320											■
631-10	334	600	340											■
694-10	400	600	400											■
734-10	436	600	440											■
790-10	466	750	470											■
887-10	543	750	550											■
988-10	617	750	620											■

Type MCECM/MCHCM														
Size DA mm	Shaft distance S		Preferred dimension V MCECM											
	MCECM min. mm	MCHCM min. mm		100	140	180	200	250	300	{127} 5"	{177.8} 7"	{228.6} 9"	-	
86-6	100	340	140		■									
103-6	100	340	140		■									
122-6	111	340	140		■									
133-6	113	340	140		■									
159-6	131	340	140		■									
174-6	132	340	140		■									
184-6	179	410	200				■							
203-6	180	410	200				■							
217-6	183	410	200				■							
251-6	219	420	250					■						
268-6	245	420	250					■						
291-6	247	420	250					■						
318-6	289	500	300						■					
343-6	290	500	300						■					

■ Preferred dimensions ■ Available standard dimensions

Type MCECM/MCHCM																
Size DA	Shaft distance S		Preferred dimension V MCECM													
	MCECM min. mm	MCHCM min. mm		100	140	180	200	250	300	(127) 5"	(177.8) 7"	(228.6) 9"	-			
219-8	207	428	218													
241-8	217	432	222													
262-8	233	438	268													
285-8	260	448	278													
302-8	285	456	286													
321-8	308	512	312													
354-8	330	516	366													
387-8	338	492	342													
411-8	350	494	394													
447-8	372	502	402													
495-8	387	706	406													
546-8	413	714	414													
587-8	435	720	440													
631-8	458	724	464													

Type MFEFM/MFHFM																
Size DA	Shaft distance S		Preferred dimension V MFEFM													
	MFEFM min. mm	MFHFM min. mm		100	140	180	200	250	300	(127) 5"	(177.8) 7"	(228.6) 9"	-			
86-6	100	340	140													
103-6	100	340	140													
122-6	111	340	140													
133-6	113	340	140													
159-6	131	340	140													
174-6	132	340	140													
184-6	179	410	200													
203-6	180	410	200													
217-6	183	410	200													
251-6	219	420	250													
268-6	245	420	250													
291-6	297	470	300													
318-6	289	500	300													
343-6	290	500	300													
219-8	207	428	218													
241-8	217	432	222													
262-8	233	438	268													
285-8	260	448	278													
302-8	285	456	286													
321-8	308	512	312													
354-8	330	516	366													
387-8	338	492	342													
411-8	350	494	394													
447-8	372	502	402													
495-8	387	706	406													
546-8	413	714	414													
587-8	435	720	440													
631-8	458	724	464													
495-10	387	706	406													
546-10	413	714	414													
587-10	435	720	440													
631-10	458	724	464													
694-10	552	752	552													
734-10	600	764	604													
790-10	646	930	650													
887-10	749	956	756													
988-10	857	900	860													

■ Preferred dimensions ■ Available standard dimensions

TYPE NEN/NHN

Torsionally rigid couplings of type NEN (NHN) with radially freely demountable intermediate spacer and catching device to secure the intermediate spacer in the event of

plate breakage. Standard coupling type in accordance with **API 610**. Coupling type in accordance with **API 671** (up to $n = 1800$ rpm) possible.

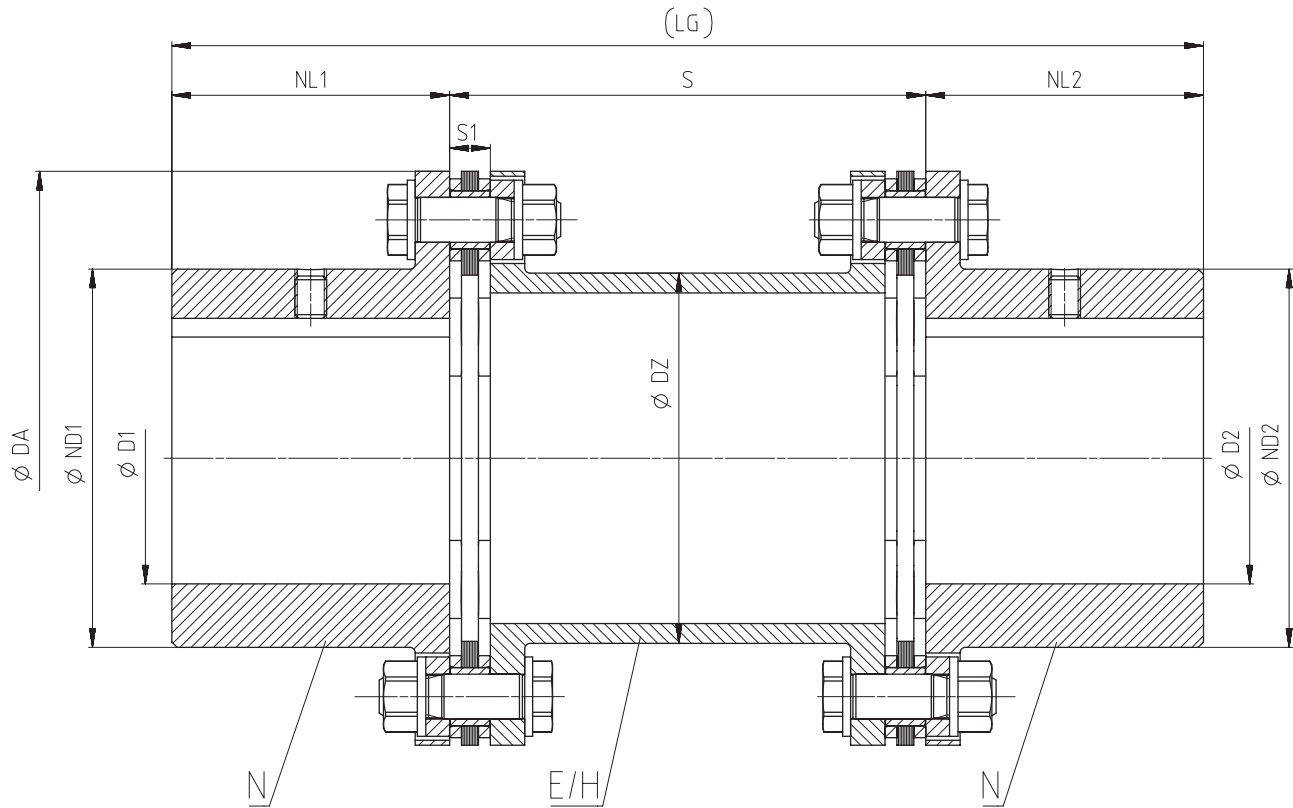

Size DA mm	Rated torque T_{KN} kNm	Maximum speed n_{Kmax} rpm	Dimensions in mm								➤ Article no. ¹⁾		Weight <i>m</i> kg	
			D1/D2 Keyway DIN 6885-1 max.	ND1/ ND2	NL1/ NL2	DZ	S1	Shaft distance S		Preferred dimension V	LG	Intermediate spacer		
								NEN min.	NHN min.	NEN		E spacer (NEN)	H spacer (NHN)	
86-6	0.35	24000	42	56	45	45	8	60	300	100	190	2LC0370-0AA	2LC0370-0AL	1.9
103-6	0.5	20000	55	73	55	60	8.4	60	300	100	210	2LC0370-1AA	2LC0370-1AL	3
122-6	0.95	17000	65	85	65	73	8.8	71	300	100	230	2LC0370-2AA	2LC0370-2AL	5.1
133-6	1.25	15000	75	96	75	85	9.6	73	300	100	250	2LC0370-3AA	2LC0370-3AL	6.4
159-6	2.1	13000	80	104	80	97	11.6	91	300	100	260	2LC0370-4AA	2LC0370-4AL	9.6
174-6	2.5	12000	90	118	85	116	12.8	92	300	100	270	2LC0370-5AA	2LC0370-5AL	11.8
184-6	3.8	11000	95	124	90	123	14.6	119	350	140	320	2LC0370-6AA	2LC0370-6AL	16.4
203-6	5	10000	100	135	95	128	15	120	350	140	330	2LC0370-7AA	2LC0370-7AL	21.3
217-6	6.2	9500	110	143	105	140	15.4	123	350	140	350	2LC0370-8AA	2LC0370-8AL	24.4
251-6	10.5	8000	120	160	110	160	20.6	149	350	180	400	2LC0371-0AA	2LC0371-0AL	38
268-6	13.8	7500	130	170	130	166	22	175	350	180	440	2LC0371-1AA	2LC0371-1AL	48.6
291-6	18.2	7000	145	190	140	188	22.8	177	350	180	460	2LC0371-2AA	2LC0371-2AL	62.8
318-6	23	6500	155	205	150	197	23.2	189	400	200	500	2LC0371-3AA	2LC0371-3AL	83.9
343-6	28	6000	170	230	160	223	24	190	400	200	520	2LC0371-4AA	2LC0371-4AL	104

¹⁾ To identify complete item numbers specifying the available finish boring options and – if necessary – further order options, please use our configurators on flender.com.

²⁾ The S shaft spacing standard dimensions available for each size can be found on Page 6/10.

➤ For online configuration on flender.com, click on the item no.

Size DA mm	Rated torque T_{KN} kNm	Maximum speed n_{Kmax} rpm	Dimensions in mm										Article no. ¹⁾		Weight <i>m</i> kg
			D1/D2 Keyway DIN 6885-1 max.	ND1/ ND2	NL1/ NL2	DZ	S1	Shaft distance S		Preferred dimension V NEN	LG	Intermediate spacer			
								NEN min.	NHN min.			E spacer (NEN)	H spacer (NHN)		
219-8	10	9500	100	137	115	124	12.2	129	350	140	370	2LC0380-0AA	2LC0380-0AL	31.9	
241-8	15	8700	110	150	127	135	12.6	135	350	140	394	2LC0380-1AA	2LC0380-1AL	41.3	
262-8	20	8000	120	163	138	148	13.8	145	350	180	456	2LC0380-2AA	2LC0380-2AL	53.8	
285-8	27	7300	130	177	150	162	15.2	162	350	180	480	2LC0380-3AA	2LC0380-3AL	70.8	
302-8	35	6900	140	192	161	174	17.2	179	350	180	502	2LC0380-4AA	2LC0380-4AL	89.4	
321-8	43	6500	150	206	173	189	21	196	400	200	546	2LC0380-5AA	2LC0380-5AL	109	
354-8	56	5900	170	232	196	216	23.6	214	400	250	642	2LC0380-6AA	2LC0380-6AL	149	
387-8	72	5400	190	258	219	240	26	246	400	250	688	2LC0380-7AA	2LC0380-7AL	193	
411-8	93	5100	200	272	230	250	29.6	256	400	300	760	2LC0380-8AA	2LC0380-8AL	236	
447-8	122	4600	220	299	253	275	32.6	270	400	300	806	2LC0381-0AA	2LC0381-0AL	299	
495-8	160	4200	250	340	288	312	33.8	281	600	300	876	2LC0381-1AA	2LC0381-1AL	402	
546-8	212	3800	280	381	322	351	40	299	600	300	944	2LC0381-2AA	2LC0381-2AL	547	
587-8	270	3500	300	408	345	363	45	315	600	320	1010	2LC0381-3AA	2LC0381-3AL	690	
631-8	350	3300	320	435	368	399	48.8	334	600	340	1076	2LC0381-4AA	2LC0381-4AL	835	
495-10	200	4200	250	340	288	312	33.8	281	600	300	876	2LC0390-0AA	2LC0390-0AL	402	
546-10	270	3800	280	381	322	351	40	299	600	300	944	2LC0390-1AA	2LC0390-1AL	547	
587-10	352	3500	300	408	345	363	45	315	600	320	1010	2LC0390-2AA	2LC0390-2AL	690	
631-10	450	3300	320	435	368	399	48.8	334	600	340	1076	2LC0390-3AA	2LC0390-3AL	834	
694-10	630	3000	350	485	403	435	58	400	600	400	1206	2LC0390-4AA	2LC0390-4AL	1213	
734-10	760	2800	370	512	426	459	63	436	600	440	1292	2LC0390-5AA	2LC0390-5AL	1463	
790-10	950	2600	400	555	460	496	66	466	750	470	1390	2LC0390-6AA	2LC0390-6AL	1837	
887-10	1400	2300	450	627	518	546	78	543	750	550	1586	2LC0390-7AA	2LC0390-7AL	2713	
988-10	2000	2100	500	696	575	596	86	617	750	620	1770	2LC0390-8AA	2LC0390-8AL	3868	

Configurable variants ¹⁾

- ØD1 Without finished bore
With finished bore
- ØD2 Without finished bore
With finished bore
- Shaft distance S ²⁾ Metric (mm): 100 mm, 140 mm, 180 mm, 200 mm, 250 mm, 300 mm
Imperial (inches): 3.5" (88.9 mm), 5" (127 mm), 7" (177.8 mm), 9" (228.6 mm)
Any required (mm)

Notes

- Spacer sleeves (type NEN) designed as electrical cable sleeves are API compliant.
- Hubs are designed with threaded pull-off holes. Special lengths available upon request.
- The total lengths and the weights apply to the whole coupling of type NEN with maximum bores D1/D2 and the preferred shaft distance S = V.
- In cases with large shaft distances S the intermediate spacer can be designed as an H-spacer. The tube diameters here may slightly diverge. More precise coupling data in cases of variable shaft distances and E- / H-spacers are given on pages 6/23 to 6/25.
- E-spacers in preferred lengths up to size 343-6 are available from stock.

Ordering example

- N-ARPEX ARN-6 NEN coupling, size 217-6, with shaft distance S = 140 mm
- Bore ØD1 50H7 mm, keyway to DIN 6885-1 P9 and set screw (L1C)
- Bore ØD2 60H7 mm, keyway to DIN 6885-1 P9 and set screw (M1E)

Article no.: 2LC0370-8AA99-0AB0-Z L1C+M1E

¹⁾ To identify complete item numbers specifying the available finish boring options and – if necessary – further order options, please use our configurators on flender.com.

²⁾ The S shaft spacing standard dimensions available for each size can be found on Page 6/10.

➤ For online configuration on flender.com, click on the item no.

TYPE MCECM/MCHCM

Torsionally rigid couplings of type MCECM (MCHCM) with radially freely demountable pre-assembled intermediate unit and catching device to secure the intermediate spacer

in the event of plate breakage. Standard coupling type in accordance with **API 610**. Coupling type in accordance with **API 671** possible.

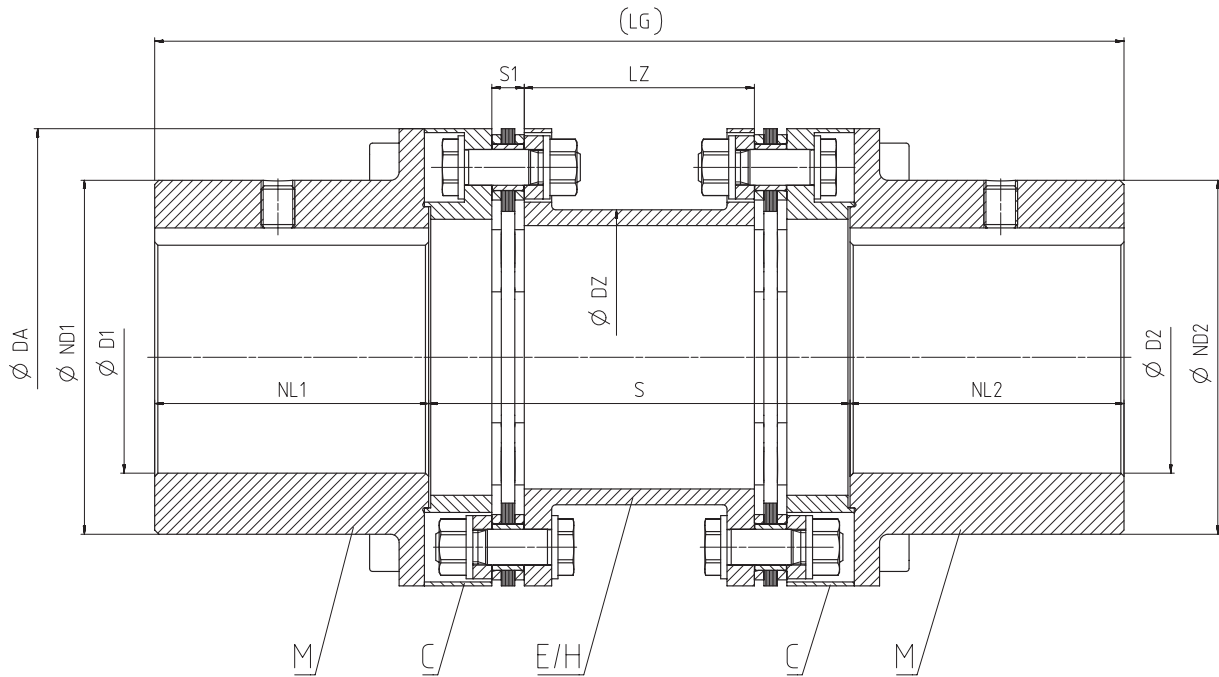

Size DA	Rated torque T_{KN}	Maximum speed n_{Kmax}	Dimensions in mm										Article no. ¹⁾		Weight <i>m</i> kg
			D1/D2 Keyway DIN 6885-1 max.	ND1/ ND2	NL1/ NL2	DZ	LZ	S1	Shaft distance S		Preferred dimension V	LG	Intermediate spacer		
mm	kNm	rpm							MCECM min.	MCHCM min.	MCECM		E spacer (MCECM)	H spacer (MCHCM)	
86-6	0.35	24000	42	62	42	45	84	8	100	340	140	224	2LC0370-0AC	2LC0370-0AM	3.1
103-6	0.5	20000	55	72	55	60	83.2	8.4	100	340	140	250	2LC0370-1AC	2LC0370-1AM	4.7
122-6	0.95	17000	70	91	70	73	82.4	8.8	111	340	140	280	2LC0370-2AC	2LC0370-2AM	7.7
133-6	1.25	15000	80	103	80	85	80.8	9.6	113	340	140	300	2LC0370-3AC	2LC0370-3AM	9.6
159-6	2.1	13000	95	123	95	97	76.8	11.6	131	340	140	330	2LC0370-4AC	2LC0370-4AM	15.9
174-6	2.5	12000	105	136	105	116	74.4	12.8	132	340	140	350	2LC0370-5AC	2LC0370-5AM	19.3

Configurable variants ¹⁾

- $\varnothing D1$ Without finished bore
With finished bore
- $\varnothing D2$ Without finished bore
With finished bore
- Shaft distance S ²⁾ Metric (mm): 100 mm, 140 mm, 180 mm, 200 mm, 250 mm, 300 mm
Imperial (inches): 5" (127 mm), 7" (177.8 mm), 9" (228.6 mm)
Any required (mm)

¹⁾ To identify complete item numbers specifying the available finish boring options and – if necessary – further order options, please use our configurators on flender.com.

²⁾ The S shaft spacing standard dimensions available for each size can be found on Page 6/10.

➤ For online configuration on flender.com, click on the item no.

Size DA	Rated torque T_{KN}	Maximum speed n_{Kmax}	Dimensions in mm											Article no. ¹⁾		Weight m
			D1/D2 Keyway DIN 6885-1 max.	ND1/ ND2	NL1/ NL2	DZ	LZ	S1	Shaft distance S		Preferred dimension V MCECM	LG	Intermediate spacer			
									MCECM min.	MCHCM min.			E spacer (MCECM)	H spacer (MCHCM)		
mm	kNm	rpm													kg	
184-6	3.8	11000	110	142	110	123	110.8	14.6	179	410	200	420	2LC0370-6AC	2LC0370-6AM	26.6	
203-6	5	10000	115	150	115	128	110	15	180	410	200	430	2LC0370-7AC	2LC0370-7AM	33.7	
217-6	6.2	9500	130	168	130	140	109.2	15.4	183	410	200	460	2LC0370-8AC	2LC0370-8AM	40.3	
251-6	10.5	8000	150	193	150	160	138.8	20.6	219	420	250	550	2LC0371-0AC	2LC0371-0AM	64.4	
268-6	13.8	7500	160	206	160	166	136	22	245	420	250	570	2LC0371-1AC	2LC0371-1AM	78.8	
291-6	18.2	7000	170	221	170	188	134.4	22.8	247	420	250	590	2LC0371-2AC	2LC0371-2AM	98.3	
318-6	23	6500	190	245	190	197	153.6	23.2	289	500	300	680	2LC0371-3AC	2LC0371-3AM	139	
343-6	28	6000	205	267	205	223	152	24	290	500	300	710	2LC0371-4AC	2LC0371-4AM	168	
219-8	10	9500	140	179	140	124	115.6	12.2	207	428	218	498	2LC0380-0AC	2LC0380-0AM	50.3	
241-8	15	8700	155	201	155	135	114.8	12.6	217	432	222	532	2LC0380-1AC	2LC0380-1AM	68.2	
262-8	20	8000	165	218	165	148	152.4	13.8	233	438	268	598	2LC0380-2AC	2LC0380-2AM	89	
285-8	27	7300	185	239	185	162	149.6	15.2	260	448	278	648	2LC0380-3AC	2LC0380-3AM	115	
302-8	35	6900	190	250	190	174	145.6	17.2	285	456	286	666	2LC0380-4AC	2LC0380-4AM	140	
321-8	43	6500	205	269	205	189	158	21	308	512	312	722	2LC0380-5AC	2LC0380-5AM	171	
354-8	56	5900	230	296	230	216	202.8	23.6	330	516	366	826	2LC0380-6AC	2LC0380-6AM	220	
387-8	72	5400	255	329	255	240	198	26	338	492	342	852	2LC0380-7AC	2LC0380-7AM	275	
411-8	93	5100	270	347	270	250	240.8	29.6	350	494	394	934	2LC0380-8AC	2LC0380-8AM	332	
447-8	122	4600	290	375	290	275	234.8	32.6	372	502	402	982	2LC0381-0AC	2LC0381-0AM	419	
495-8	160	4200	325	423	325	312	232.4	33.8	387	706	406	1056	2LC0381-1AC	2LC0381-1AM	561	
546-8	212	3800	360	468	360	351	220	40	413	714	414	1134	2LC0381-2AC	2LC0381-2AM	752	
587-8	270	3500	380	499	380	363	230	45	435	720	440	1200	2LC0381-3AC	2LC0381-3AM	945	
631-8	350	3300	410	535	410	399	242.4	48.8	458	724	464	1284	2LC0381-4AC	2LC0381-4AM	1146	

Configurable variants ¹⁾

- ØD1 Without finished bore
With finished bore
- ØD2 Without finished bore
With finished bore
- Shaft distance S ²⁾ Metric (mm): 100 mm, 140 mm, 180 mm, 200 mm, 250 mm, 300 mm
Imperial (inches): 5" (127 mm), 7" (177.8 mm), 9" (228.6 mm)
Any required (mm)

Notes

- Spacer sleeves (type MCECM) designed as electrical cable sleeves are API compliant.
- Hubs are designed with threaded pull-off holes. Special lengths available upon request.
- The total lengths, the spacer lengths and the weights apply to the whole coupling of type MCECM with maximum bores D1/D2 and the preferred shaft distance S = V.
- In cases with large shaft distances S the intermediate spacer can be designed as an H-spacer. The tube diameters here may slightly diverge. More precise coupling data in cases of variable shaft distances and E- / H-spacers are given on pages 6/23 to 6/25.
- Plate packs in the CEC/CHC intermediate unit assembled at the factory.
- E-spacers in preferred lengths up to size 343-6 are available from stock.

Ordering example

- N-ARPEX ARN-6 MCECM coupling, size 217-6, with shaft distance S = 200 mm
- Bore ØD1 60H7 mm, keyway to DIN 6885-1 P9 and set screw **(L1G)**
- Bore ØD2 70H7 mm, keyway to DIN 6885-1 P9 and set screw **(M1G)**

Article no.: 2LC0370-8AC99-0AD0-Z L1G+M1G

¹⁾ To identify complete item numbers specifying the available finish boring options and – if necessary – further order options, please use our configurators on flender.com.

²⁾ The S shaft spacing standard dimensions available for each size can be found on Page 6/10.

➤ For online configuration on flender.com, click on the item no.

TYPE MFEFM/MFHFM

Torsionally rigid type MFEFM (MFHFM) couplings with enlarged bore capacity and radially freely demountable intermediate unit and catching device to secure the inter-

mediate spacer in the event of plate breakage. Standard coupling type in accordance with **API 610**. Coupling type in accordance with **API 671** possible.

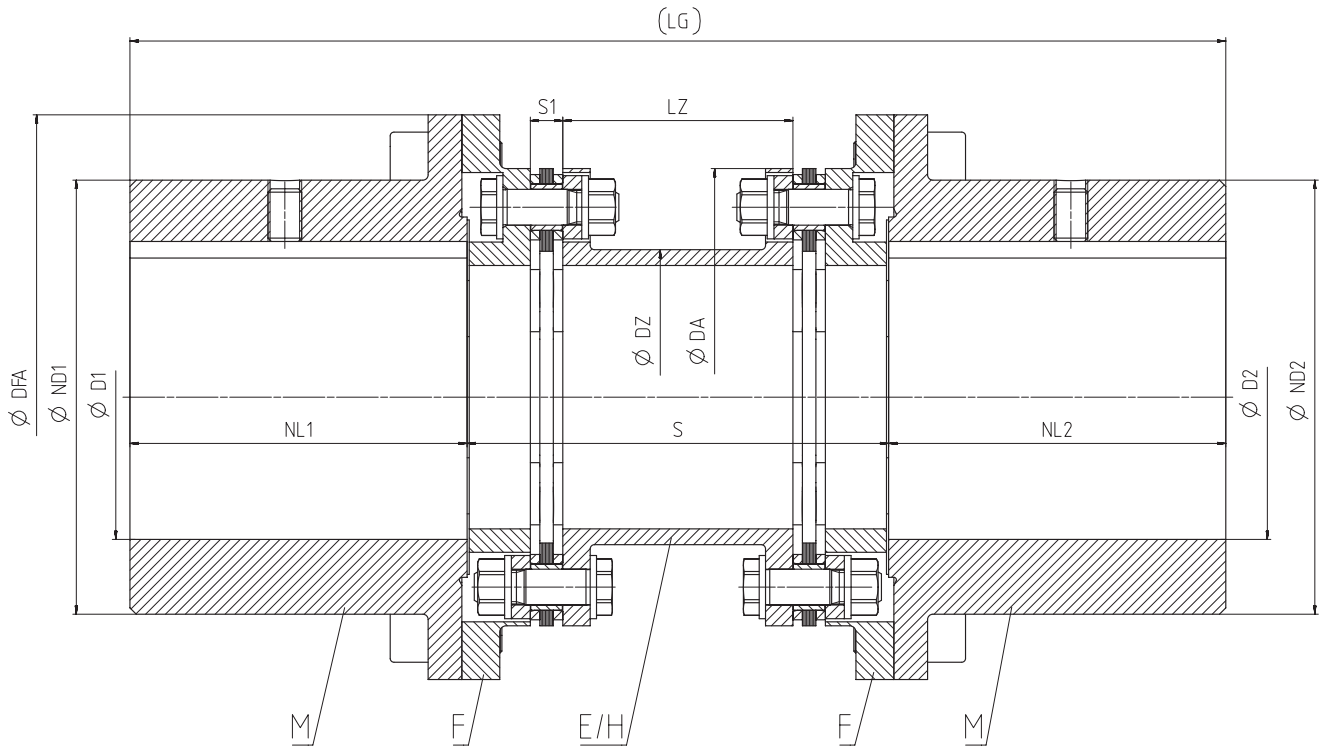

Size	Rated torque	Maximum speed	Dimensions in mm											Article no. ¹⁾		Weight	
			DA	D1/D2 Keyway DIN 6885-1	ND1/ND2	NL1/NL2	DZ	LZ	S1	Shaft distance S		Preferred dimension V	LG	Intermediate spacer			m
mm	kNm	rpm		max.							MFEFM min.	MFHFM min.	MFEFM		E spacer (MFEFM)	H spacer (MFHFM)	kg
86-6	0.35	17000	122	70	91	70	45	84	8	100	340	140	140	280	2LC0370-0BA	2LC0370-0BC	6
103-6	0.5	15000	133	80	103	80	60	83.2	8.4	100	340	140	140	300	2LC0370-1BA	2LC0370-1BC	8
122-6	0.95	13000	159	95	123	95	73	82.4	8.8	111	340	140	140	330	2LC0370-2BA	2LC0370-2BC	13.6
133-6	1.25	12000	174	105	136	105	85	80.8	9.6	113	340	140	140	350	2LC0370-3BA	2LC0370-3BC	17.1
159-6	2.1	10000	203	115	150	115	97	76.8	11.6	131	340	140	140	370	2LC0370-4BA	2LC0370-4BC	22.9
174-6	2.5	9500	217	130	168	130	116	74.4	12.8	132	340	140	140	400	2LC0370-5BA	2LC0370-5BC	26.8
184-6	3.8	8000	251	150	193	150	123	110.8	14.6	179	410	200	200	500	2LC0370-6BA	2LC0370-6BC	40.1
203-6	5	8000	251	150	193	150	128	110	15	180	410	200	200	500	2LC0370-7BA	2LC0370-7BC	52.8
217-6	6.2	7500	268	160	206	160	140	109.2	15.4	183	410	200	200	520	2LC0370-8BA	2LC0370-8BC	63.4
251-6	10.5	6500	318	190	245	190	160	138.8	20.6	219	420	250	250	630	2LC0371-0BA	2LC0371-0BC	109

Configurable variants ¹⁾

- ØD1 Without finished bore
With finished bore
- ØD2 Without finished bore
With finished bore
- Shaft distance S ²⁾ Metric (mm): 100 mm, 140 mm, 180 mm, 200 mm, 250 mm, 300 mm
Imperial (inches): 5" (127 mm), 7" (177.8 mm), 9" (228.6 mm)
Any required (mm)

¹⁾ To identify complete item numbers specifying the available finish boring options and – if necessary – further order options, please use our configurators on flender.com.

²⁾ The S shaft spacing standard dimensions available for each size can be found on [Page 6/10](http://flender.com).

➤ For online configuration on flender.com, click on the item no.

Size DA	Rated torque T_{KN}	Maximum speed n_{Kmax}	Dimensions in mm											Article no. ¹⁾		Weight <i>m</i> kg
			DFA	D1/D2 Keyway DIN 6885-1 max.	ND1/ ND2	NL1/ NL2	DZ	LZ	S1	Shaft distance S		Preferred dimension V MFEFM	LG	Intermediate spacer		
										MFEFM min.	MFHFM min.			E spacer (MFEFM)	H spacer (MFHFM)	
268-6	13.8	6000	343	205	267	205	166	136	22	245	420	250	660	2LC0371-1BA	2LC0371-1BC	136
291-6	18.2	5500	356	230	302	230	188	134.4	22.8	297	470	300	760	2LC0371-2BA	2LC0371-2BC	190
318-6	23	5500	375	245	321	245	197	153.6	23.2	289	500	300	790	2LC0371-3BA	2LC0371-3BC	221
343-6	28	4500	424	270	354	270	223	152	24	290	500	300	840	2LC0371-4BA	2LC0371-4BC	284
219-8	10	7800	267	165	219	165	124	115.6	12.2	207	428	218	548	2LC0380-0BA	2LC0380-0BC	77.7
241-8	15	7200	289	185	241	185	135	114.8	12.6	217	432	222	592	2LC0380-1BA	2LC0380-1BC	98.6
262-8	20	6600	314	200	262	200	148	152.4	13.8	233	438	268	668	2LC0380-2BA	2LC0380-2BC	131
285-8	27	6100	339	215	285	215	162	149.6	15.2	260	448	278	708	2LC0380-3BA	2LC0380-3BC	169
302-8	35	5900	356	230	302	230	174	145.6	17.2	285	456	286	746	2LC0380-4BA	2LC0380-4BC	200
321-8	43	5600	375	245	321	245	189	158	21	308	512	312	802	2LC0380-5BA	2LC0380-5BC	237
354-8	56	4900	424	270	354	270	216	202.8	23.6	330	516	366	906	2LC0380-6BA	2LC0380-6BC	315
387-8	72	4500	457	295	387	295	240	198	26	338	492	342	932	2LC0380-7BA	2LC0380-7BC	384
411-8	93	4300	481	315	411	315	250	240.8	29.6	350	494	394	1024	2LC0380-8BA	2LC0380-8BC	460
447-8	122	4000	519	340	447	340	275	234.8	32.6	372	502	402	1082	2LC0381-0BA	2LC0381-0BC	586
495-8	160	3700	567	380	495	380	312	232.4	33.8	387	706	406	1166	2LC0381-1BA	2LC0381-1BC	758
546-8	212	3300	624	420	546	420	351	220	40	413	714	414	1254	2LC0381-2BA	2LC0381-2BC	1011
587-8	270	3100	669	450	587	450	363	230	45	435	720	440	1340	2LC0381-3BA	2LC0381-3BC	1270
631-8	350	2900	719	480	631	480	399	242.4	48.8	458	724	464	1424	2LC0381-4BA	2LC0381-4BC	1581
495-10	200	3700	567	380	495	380	312	232.4	33.8	387	706	406	1166	2LC0390-0BA	2LC0390-0BC	757
546-10	270	3300	624	420	546	420	351	220	40	413	714	414	1254	2LC0390-1BA	2LC0390-1BC	1010
587-10	350	3100	669	450	587	450	363	230	45	435	720	440	1340	2LC0390-2BA	2LC0390-2BC	1268
631-10	450	2900	719	480	631	480	399	242.4	48.8	458	724	464	1424	2LC0390-3BA	2LC0390-3BC	1578
694-10	630	2600	790	530	694	530	435	284	58	552	752	552	1612	2LC0390-4BA	2LC0390-4BC	2165
734-10	750	2500	830	560	734	560	459	314	63	600	764	604	1724	2LC0390-5BA	2LC0390-5BC	2586
790-10	950	2300	896	600	790	600	496	338	66	646	930	650	1850	2LC0390-6BA	2LC0390-6BC	3263
887-10	1400	2000	1013	680	887	680	546	394	78	749	956	756	2116	2LC0390-7BA	2LC0390-7BC	4716
988-10	2000	1800	1114	760	988	760	596	448	86	857	900	860	2380	2LC0390-8BA	2LC0390-8BC	6574

Configurable variants¹⁾

- ØD1 Without finished bore
With finished bore
- ØD2 Without finished bore
With finished bore
- Shaft distance S ²⁾ Metric (mm): 100 mm, 140 mm, 180 mm,
200 mm, 250 mm, 300 mm
Imperial (inches): 5" (127 mm), 7" (177.8 mm),
9" (228.6 mm)
Any required (mm)

Notes

- Spacer sleeves (type MFEFM) designed as electrical cable sleeves are API compliant.
- Hubs are designed with threaded pull-off holes. Special lengths available upon request.
- The total lengths, the spacer lengths and the weights apply to the whole coupling of type MFEFM with maximum bores D1/D2 and the preferred shaft distance S = V.
- In cases with large shaft distances S the intermediate spacer can be designed as an H-spacer. The tube diameters here may slightly diverge. More precise coupling data in cases of variable shaft distances and E- / H-spacers are given on pages 6/23 to 6/25.
- Plate packs in the FEF/FHF intermediate unit assembled at the factory.
- E-spacers in preferred lengths up to size 343-6 are available from stock.

Ordering example

- N-ARPEX ARN-6 MFEFM coupling, size 217-6, with shaft distance S = 200 mm
- Bore ØD1 80H7 mm, keyway to DIN 6885-1 P9 and set screw **(L1J)**
- Bore ØD2 90H7 mm, keyway to DIN 6885-1 P9 and set screw **(M1L)**

Article no.: **2LC0370-8BA99-0AD0-Z L1J+M1L**

¹⁾ To identify complete item numbers specifying the available finish boring options and – if necessary – further order options, please use our configurators on flender.com.

²⁾ The S shaft spacing standard dimensions available for each size can be found on Page 6/10.

➤ For online configuration on flender.com, click on the item no.

TYPE BEB

Torsionally rigid type BEB couplings with smallest possible shaft distance.

Type BEB cannot be freely demounted radially without shifting the units.

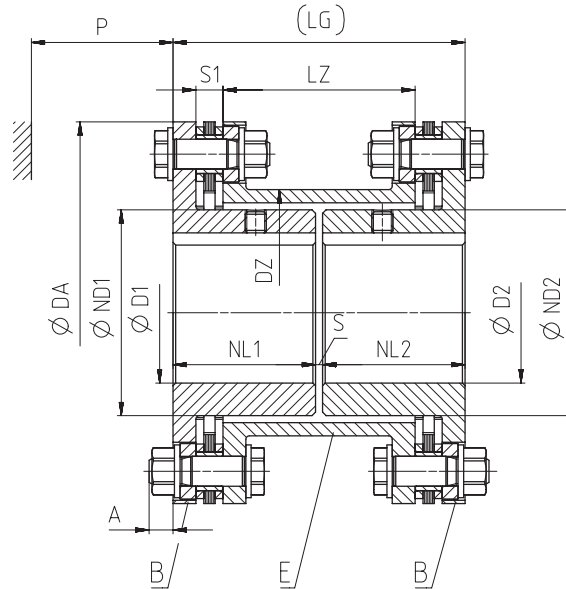

Size DA mm	Rated torque T_{KN} kNm	Maximum speed n_{Kmax} rpm	Dimensions in mm										Article no. ¹⁾	Weight m kg
			D1/D2 Keyway DIN 6885-1 max.	ND1/ ND2	NL1/ NL2	DZ	LZ	S1	Shaft distance S	A	P	LG		
86-6	350	24000	22	35	30	45	44	8	12	8	32	72	SLC0370-0AB	1.5
103-6	500	20000	38	50	34	60	43.2	8.4	4	8	32	72	SLC0370-1AB	2.0
122-6	950	17000	48	62	56	73	82.4	8.8	4	8	38	116	2LC0370-2AB	4.2
133-6	1250	15000	55	72	56	85	80.8	9.6	4	7	38	116	2LC0370-3AB	5.1
159-6	2100	13000	65	84	57	97	76.8	11.6	6	9	48	120	2LC0370-4AB	8.1
174-6	2500	12000	75	102	77	116	114.4	12.8	4	10	48	158	2LC0370-5AB	11.4
184-6	3800	11000	80	106	80	123	110.8	14.6	6	15	64	166	2LC0370-6AB	15.2
203-6	5000	10000	85	111	80	128	110	15	6	14	64	166	2LC0370-7AB	18.2
217-6	6200	9500	90	124	81	140	109.2	15.4	4	14	66	166	2LC0370-8AB	22.0
251-6	10500	8000	100	137	102	160	138.8	20.6	6	15	77	210	2LC0371-0AB	35.6
268-6	13800	7500	108	143	105	166	136	22	12	11	89	222	2LC0371-1AB	44.8
291-6	18200	7000	120	162	106	188	134.4	22.8	10	11	89	222	2LC0371-2AB	56.7
318-6	23000	6500	130	164	118	197	153.6	23.2	6	20	100	242	2LC0371-3AB	70.2
343-6	28000	6000	150	186	143	223	202	24	6	19	100	292	2LC0371-4AB	87.7

Configurable variants ¹⁾

- $\varnothing D1$ Without finished bore
With finished bore
- $\varnothing D2$ Without finished bore
With finished bore

Notes

- Hubs are designed with threaded pull-off holes. Special lengths available upon request.
- The total lengths and the weights apply to the whole coupling with maximum bores D1/D2 and the preferred shaft distance $S = V$.

¹⁾ To identify complete item numbers specifying the available finish boring options and – if necessary – further order options, please use our configurators on flender.com.

Ordering example

- N-ARPEX ARN-6 BEB coupling, size 217-6, with shaft distance $S = 4$ mm
- Bore $\varnothing D1$ 50H7 mm, keyway to DIN 6885-1 and set screw **(L1C)**
- Bore $\varnothing D2$ 60H7 mm, keyway to DIN 6885-1 and set screw **(M1E)**

Article no.: **2LC0370-8AB99-0AA0-Z L1C+M1E**

➤ For online configuration on flender.com, click on the item no.

FURTHER HUBS

Clamping hubs, type 124 and 125

Type 124 and 125 standard clamping hubs can be combined with any spacer of the ARN-6 series.

It should be noted that the clamping hub can be used only as an "N hub" (hub core outside).

Function

N-ARPEX clamping hubs transmit torque with the aid of a flexible press fit. By pulling the clamping ring on by means of the tightening screws the necessary surface pressure

is applied in the "shaft/hub" contact area. After the tightening operation the clamping ring lies up against the clamping hub.

Transmissible torque

The clamping connections are designed to enable the specified maximum torques to be transmitted.

These maximum torques must not be exceeded, even in the case of overload.

Fitting clearance and surface roughness

The transmissible torques allow for the maximum fitting clearance for a quality IT6 bore and shaft and maximum surface roughness. For other shaft tolerances reduced torques or other bore tolerances must be used. The surface roughness of the shaft should be $\leq Ra = 1.6 \mu m$.

The fit pairing G6/h6 should be used wherever possible. Divergent shaft tolerances must be specified when ordering. The article no. for the specification must end in "-Z" and include the code "Y26" for the fit.

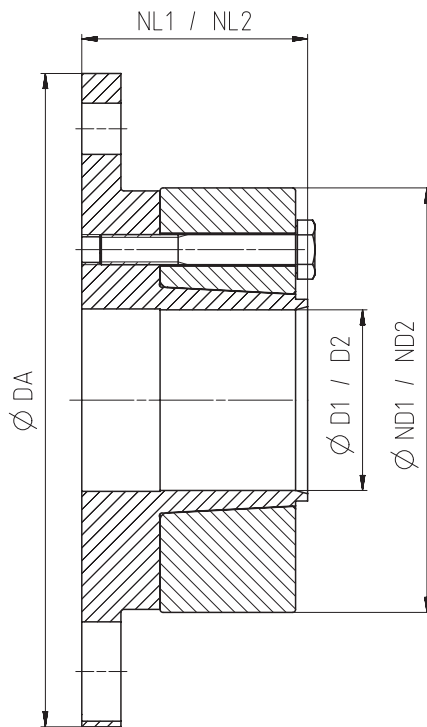

Type 124 (standard type)

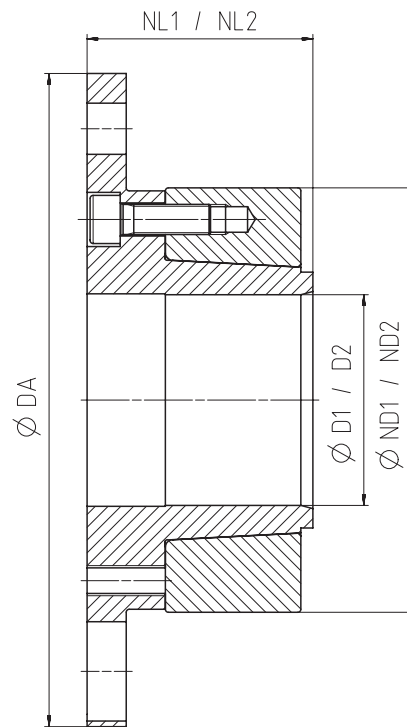

Type 125

FURTHER HUBS

Clamping hubs, type 124 and 125

Size DA mm	Clamping hub Type	Dimensions in mm		ND1/ND2	NL1/NL2	Mass moment of inertia <i>J</i> kgm ²	↗ Article no. ¹⁾	Weight <i>m</i> kg
		D1/D2 min.	max.					
86-6	124	19	25	50	35	0.0003	2LC0370-0LM90-0AA0 2LC0370-0LN90-0AA0	0.5
	125							
103-6	124	25	38	67	40	0.0009	2LC0370-1LM90-0AA0 2LC0370-1LN90-0AA0	0.9
	125							
122-6	124	30	42	77	45	0.0021	2LC0370-2LM90-0AA0 2LC0370-2LN90-0AA0	1.5
	125							
133-6	124	32	50	88	50	0.0034	2LC0370-3LM90-0AA0 2LC0370-3LN90-0AA0	2
	125							
159-6	124	35	60	105	55	0.0077	2LC0370-4LM90-0AA0 2LC0370-4LN90-0AA0	3.2
	125							
174-6	124	40	70	120	65	0.0135	2LC0370-5LM90-0AA0 2LC0370-5LN90-0AA0	4.6
	125							
184-6	124	45	70	126	70	0.0195	2LC0370-6LM90-0AA0 2LC0370-6LN90-0AA0	5.9
	125							
203-6	124	50	80	139	75	0.0298	2LC0370-7LM90-0AA0 2LC0370-7LN90-0AA0	7.4
	125							
217-6	124	60	90	147	90	0.0429	2LC0370-8LM90-0AA0 2LC0370-8LN90-0AA0	9.2
	125							
251-6	124	70	95	168	95	0.0837	2LC0371-0LM90-0AA0 2LC0371-0LN90-0AA0	14
	125							
268-6	124	75	100	175	115	0.1236	2LC0371-1LM90-0AA0 2LC0371-1LN90-0AA0	18.5
	125							
291-6	124	80	120	195	125	0.1907	2LC0371-2LM90-0AA0 2LC0371-2LN90-0AA0	22.9
	125							
318-6	124	85	120	209	140	0.2975	2LC0371-3LM90-0AA0 2LC0371-3LN90-0AA0	31.5
	125							
343-6	124	95	140	234	150	0.4539	2LC0371-4LM90-0AA0 2LC0371-4LN90-0AA0	39.6
	125							

Note

- Weights and mass moments of inertia apply to a clamping hub with a maximum bore D1/D2.

Ordering example:

- N-ARPEX clamping hub, type 124, size 133-6
- Shaft ØD1 = 40k6 (**L0W**)

- Y26** / fit specification supplied

Article no.: 2LC0370-3LM90-0AA0-Z L0W+Y26

Plain text Y26: k6

¹⁾ To identify complete item numbers specifying the available finish boring options and – if necessary – further order options, please use our configurators on [flender.com](https://www.flender.com).

↗ For online configuration on [flender.com](https://www.flender.com), click on the item no.

Dimensions and torques

Finished bore/shaft in standard fit	DA size in mm													
	86-6	103-6	122-6	133-6	159-6	174-6	184-6	203-6	217-6	251-6	268-6	291-6	318-6	343-6
D1 ⁶⁴ / _{h6} mm	Rated coupling torque T_{KN} in Nm													
	350	500	950	1250	2100	2400	3800	5000	6200	10500	13800	18200	23000	28000
	Maximum transmissible torque of the clamping hub													
	Nm													
19	400	-	-	-	-	-	-	-	-	-	-	-	-	-
20	460	-	-	-	-	-	-	-	-	-	-	-	-	-
22	470	-	-	-	-	-	-	-	-	-	-	-	-	-
24	350	-	-	-	-	-	-	-	-	-	-	-	-	-
25	370	480	-	-	-	-	-	-	-	-	-	-	-	-
28	-	870	-	-	-	-	-	-	-	-	-	-	-	-
30	-	1150	1770	-	-	-	-	-	-	-	-	-	-	-
32	-	1140	1830	2300	-	-	-	-	-	-	-	-	-	-
35	-	570	1420	2360	3050	-	-	-	-	-	-	-	-	-
38	-	830	1720	3040	2710	-	-	-	-	-	-	-	-	-
40	-	-	1370	2610	3660	3680	-	-	-	-	-	-	-	-
42	-	-	1670	2930	2180	4020	-	-	-	-	-	-	-	-
45	-	-	-	2120	3750	4110	5780	-	-	-	-	-	-	-
48	-	-	-	2480	4160	4930	6200	-	-	-	-	-	-	-
50	-	-	-	2240	2300	4300	5840	7190	-	-	-	-	-	-
55	-	-	-	-	3310	5370	6410	7970	-	-	-	-	-	-
60	-	-	-	-	3260	3730	5370	8840	7570	-	-	-	-	-
65	-	-	-	-	-	4700	6240	8890	10390	-	-	-	-	-
70	-	-	-	-	-	4150	5920	8460	10640	14050	-	-	-	-
75	-	-	-	-	-	-	-	7960	9590	15350	20710	-	-	-
80	-	-	-	-	-	-	-	7340	8850	13510	20120	31840	-	-
85	-	-	-	-	-	-	-	-	7890	16370	21130	31230	36420	-
90	-	-	-	-	-	-	-	-	6290	14300	20810	33300	39050	-
95	-	-	-	-	-	-	-	-	-	13310	18570	33530	35940	54230
100	-	-	-	-	-	-	-	-	-	-	14440	31710	37500	56580
110	-	-	-	-	-	-	-	-	-	-	-	29020	35200	56900
120	-	-	-	-	-	-	-	-	-	-	-	22600	31490	53580
130	-	-	-	-	-	-	-	-	-	-	-	-	-	50910
140	-	-	-	-	-	-	-	-	-	-	-	-	-	43600

Note

- The maximum transmissible torque of the clamping hub must not be exceeded! Further clamping hub sizes and higher torques on request.

SPARE AND WEAR PARTS

Plate pack

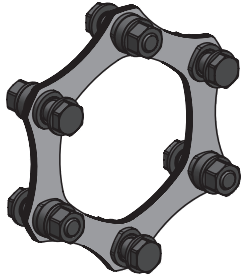

Size 86-6 to 343-6
(hexagon plates)

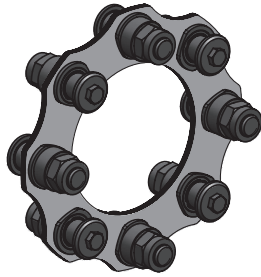

Size 219-8 to 631-8
(octagon plates)

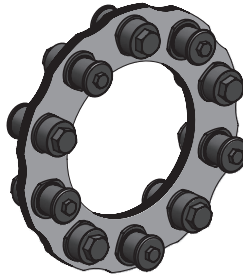

Size 495-10 to 631-10
(decagon plates)

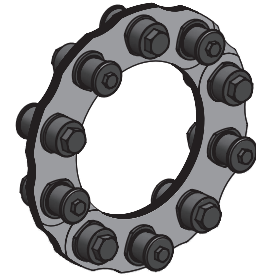

Size 694-10 to 988-10
(decagon plates/segment)

6

Size	Dimensions	Mass moment of inertia	Article No.	Weight
DA	S1 mm	J kgm ²		m kg
86-6	8	0.00018	2LC0370-0LP00-0AA0	0.17
103-6	8.4	0.00032	2LC0370-1LP00-0AA0	0.19
122-6	8.8	0.001	2LC0370-2LP00-0AA0	0.43
133-6	9.6	0.0014	2LC0370-3LP00-0AA0	0.49
159-6	11.6	0.0033	2LC0370-4LP00-0AA0	0.8
174-6	12.8	0.0047	2LC0370-5LP00-0AA0	0.93
184-6	14.6	0.0078	2LC0370-6LP00-0AA0	1.38
203-6	15	0.012	2LC0370-7LP00-0AA0	1.79
217-6	15.4	0.018	2LC0370-8LP00-0AA0	2.25
251-6	20.6	0.037	2LC0371-0LP00-0AA0	3.61
268-6	22	0.056	2LC0371-1LP00-0AA0	4.83
291-6	22.8	0.08	2LC0371-2LP00-0AA0	5.78
318-6	23.2	0.13	2LC0371-3LP00-0AA0	8.12
343-6	24	0.17	2LC0371-4LP00-0AA0	8.68
219-8	12.2	0.028	2LC0380-0LP00-0AA0	3.58
241-8	12.6	0.042	2LC0380-1LP00-0AA0	4.67
262-8	13.8	0.067	2LC0380-2LP00-0AA0	6.05
285-8	15.2	0.11	2LC0380-3LP00-0AA0	8.28
302-8	17.2	0.15	2LC0380-4LP00-0AA0	10.3
321-8	21	0.22	2LC0380-5LP00-0AA0	13.6
354-8	23.6	0.34	2LC0380-6LP00-0AA0	17
387-8	26	0.49	2LC0380-7LP00-0AA0	20.2
411-8	29.6	0.7	2LC0380-8LP00-0AA0	26
447-8	32.6	1.01	2LC0381-0LP00-0AA0	31.5
495-8	33.8	1.54	2LC0381-1LP00-0AA0	38.7
546-8	40	2.57	2LC0381-2LP00-0AA0	52.9
587-8	45	3.74	2LC0381-3LP00-0AA0	67.2
631-8	48.8	5.38	2LC0381-4LP00-0AA0	85
495-10	33.8	1.76	2LC0390-0LP00-0AA0	43.4
546-10	40	2.9	2LC0390-1LP00-0AA0	58.5
587-10	45	4.19	2LC0390-2LP00-0AA0	73.7
631-10	48.8	5.98	2LC0390-3LP00-0AA0	92.6
694-10	58	11.8	2LC0390-4LP00-0AA0	148
734-10	63	16.3	2LC0390-5LP00-0AA0	182
790-10	66	23.4	2LC0390-6LP00-0AA0	226
887-10	78	43.7	2LC0390-7LP00-0AA0	335
988-10	86	75.8	2LC0390-8LP00-0AA0	468

Notes

- The plate pack of the ARN-6/-8 series is readily available as a spare part.
- The plate pack is delivered with screw connection.
- Mainly ring plates are used for the plate packs. Sizes 694-10 to 988-10 plate packs are designed with segmented plates.

Ordering example

- N-ARPEX ARN-8 plate pack, size 354-8, complete with screw connection

Article no.: 2LC0380-6LP00-0AA0

LENGTH-DEPENDENT SPECIFICATIONS

of types NEN/ NHN, BEB, MCECM/MCHCM and MFEFM/MFHFM

A variant with an E-spacer is standardly provided for each N-ARPEX type. This has been machined all over in accordance with the requirements of **API 610** and **671**. Particularly for large shaft distances *S* and therefore for correspondingly long intermediate spacer it is usual to leave the inside and outside diameters of the tube in the condition in which it was delivered. These spacers are then referred to as H-spacers.

If a coupling is fitted with an H-spacer, the type designation changes accordingly. For example, an NEN becomes an NHN, an MFEFM becomes an MFHFN. No version with an H-spacer is provided for the BEB type. Length-dependent technical specifications for the various coupling types are shown on the following table.

The shaft distance *S* must be specified in mm. The specifications with regard to weight and mass moment of inertia refer to the whole coupling with maximum bores *D*1/ *D*2.

The values for torsional stiffness apply to the whole coupling (not including the hubs and customer shafts) and refer to the rated coupling torque T_{KN} . For determination of torsional stiffness for a specific operating point outside the nominal range Flender must be consulted.

Variant with E spacer

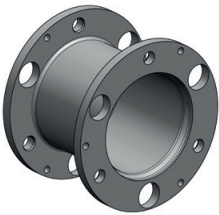

Size DA	Type	<i>m</i> kg	<i>J</i> kgm ²	<i>C</i> MNm/rad
86-6	NEN	1.55 + 0.003 · <i>S</i>	0.001 + 0.000002 · <i>S</i>	1/(1/0,08 + <i>S</i> /15)
	BEB	1.42 + 0.003 · <i>S</i>	0.001 + 0.000002 · <i>S</i>	1/(1/0,06 + <i>S</i> /15)
	MCECM	2.64 + 0.003 · <i>S</i>	0.003 + 0.000002 · <i>S</i>	1/(1/0,09 + <i>S</i> /15)
	MFEFM	5.54 + 0.003 · <i>S</i>	0.01 + 0.000002 · <i>S</i>	1/(1/0,09 + <i>S</i> /15)
103-6	NEN	2.52 + 0.005 · <i>S</i>	0.004 + 0.000004 · <i>S</i>	1/(1/0,11 + <i>S</i> /42)
	BEB	2.01 + 0.005 · <i>S</i>	0.003 + 0.000004 · <i>S</i>	1/(1/0,1 + <i>S</i> /42)
	MCECM	4 + 0.005 · <i>S</i>	0.006 + 0.000004 · <i>S</i>	1/(1/0,12 + <i>S</i> /42)
	MFEFM	7.28 + 0.005 · <i>S</i>	0.017 + 0.000004 · <i>S</i>	1/(1/0,12 + <i>S</i> /42)
122-6	NEN	4.39 + 0.007 · <i>S</i>	0.009 + 0.000008 · <i>S</i>	1/(1/0,26 + <i>S</i> /82)
	BEB	4.19 + 0.007 · <i>S</i>	0.008 + 0.000008 · <i>S</i>	1/(1/0,2 + <i>S</i> /82)
	MCECM	6.78 + 0.007 · <i>S</i>	0.015 + 0.000008 · <i>S</i>	1/(1/0,29 + <i>S</i> /82)
	MFEFM	12.6 + 0.007 · <i>S</i>	0.042 + 0.000008 · <i>S</i>	1/(1/0,29 + <i>S</i> /82)
133-6	NEN	5.5 + 0.009 · <i>S</i>	0.013 + 0.000014 · <i>S</i>	1/(1/0,33 + <i>S</i> /142)
	BEB	5.09 + 0.009 · <i>S</i>	0.011 + 0.000014 · <i>S</i>	1/(1/0,27 + <i>S</i> /142)
	MCECM	8.44 + 0.009 · <i>S</i>	0.023 + 0.000014 · <i>S</i>	1/(1/0,36 + <i>S</i> /142)
	MFEFM	15.86 + 0.009 · <i>S</i>	0.064 + 0.000014 · <i>S</i>	1/(1/0,36 + <i>S</i> /142)
159-6	NEN	8.54 + 0.011 · <i>S</i>	0.028 + 0.000023 · <i>S</i>	1/(1/0,54 + <i>S</i> /234)
	BEB	8 + 0.011 · <i>S</i>	0.026 + 0.000023 · <i>S</i>	1/(1/0,45 + <i>S</i> /234)
	MCECM	14.35 + 0.011 · <i>S</i>	0.055 + 0.000023 · <i>S</i>	1/(1/0,6 + <i>S</i> /234)
	MFEFM	21.37 + 0.011 · <i>S</i>	0.068 + 0.000023 · <i>S</i>	1/(1/0,6 + <i>S</i> /234)

Variant with H spacer

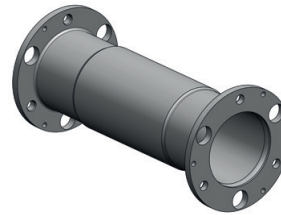

Size DA	Type	<i>m</i> kg	<i>J</i> kgm ²	<i>C</i> MNm/rad
86-6	NHN	1.11 + 0.005 · <i>S</i>	0.001 + 0.000003 · <i>S</i>	1/(1/0,05 + <i>S</i> /25)
	-	-	-	-
	MCHCM	2.13 + 0.005 · <i>S</i>	0.003 + 0.000003 · <i>S</i>	1/(1/0,06 + <i>S</i> /25)
	MFHFM	5.03 + 0.005 · <i>S</i>	0.01 + 0.000003 · <i>S</i>	1/(1/0,06 + <i>S</i> /25)
103-6	NHN	1.91 + 0.008 · <i>S</i>	0.003 + 0.000007 · <i>S</i>	1/(1/0,09 + <i>S</i> /68)
	-	-	-	-
	MCHCM	3.28 + 0.008 · <i>S</i>	0.006 + 0.000007 · <i>S</i>	1/(1/0,1 + <i>S</i> /68)
	MFHFM	6.56 + 0.008 · <i>S</i>	0.016 + 0.000007 · <i>S</i>	1/(1/0,1 + <i>S</i> /68)
122-6	NHN	3.72 + 0.01 · <i>S</i>	0.008 + 0.000012 · <i>S</i>	1/(1/0,21 + <i>S</i> /122)
	-	-	-	-
	MCHCM	6 + 0.01 · <i>S</i>	0.014 + 0.000012 · <i>S</i>	1/(1/0,22 + <i>S</i> /122)
	MFHFM	11.82 + 0.01 · <i>S</i>	0.041 + 0.000012 · <i>S</i>	1/(1/0,22 + <i>S</i> /122)
133-6	NHN	4.52 + 0.013 · <i>S</i>	0.012 + 0.000022 · <i>S</i>	1/(1/0,28 + <i>S</i> /221)
	-	-	-	-
	MCHCM	7.29 + 0.013 · <i>S</i>	0.021 + 0.000022 · <i>S</i>	1/(1/0,29 + <i>S</i> /221)
	MFHFM	14.71 + 0.013 · <i>S</i>	0.062 + 0.000022 · <i>S</i>	1/(1/0,29 + <i>S</i> /221)
159-6	NHN	7.17 + 0.017 · <i>S</i>	0.025 + 0.000037 · <i>S</i>	1/(1/0,45 + <i>S</i> /373)
	-	-	-	-
	MCHCM	12.76 + 0.017 · <i>S</i>	0.051 + 0.000037 · <i>S</i>	1/(1/0,47 + <i>S</i> /373)
	MFHFM	19.78 + 0.017 · <i>S</i>	0.064 + 0.000037 · <i>S</i>	1/(1/0,47 + <i>S</i> /373)

LENGTH-DEPENDENT SPECIFICATIONS

of types NEN/ NHN, BEB, MCECM/MCHCM and MFEFM/MFHFM

Variant with E spacer

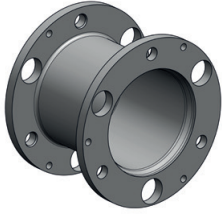

Variant with H spacer

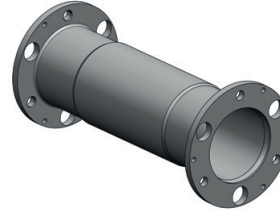

6

Size DA	Type	m kg	J kgm ²	C MNm/rad
174-6	NEN	10.57 + 0.013 · S	0.042 + 0.000039 · S	1/(1/0,64 + S/394)
	BEB	11.36 + 0.013 · S	0.041 + 0.000039 · S	1/(1/0,52 + S/394)
	MCECM	17.54 + 0.013 · S	0.08 + 0.000039 · S	1/(1/0,68 + S/394)
	MFEFM	25.02 + 0.013 · S	0.146 + 0.000039 · S	1/(1/0,68 + S/394)
184-6	NEN	13.94 + 0.017 · S	0.065 + 0.000059 · S	1/(1/1 + S/597)
	BEB	15.1 + 0.017 · S	0.066 + 0.000059 · S	1/(1/0,81 + S/597)
	MCECM	23.12 + 0.017 · S	0.081 + 0.000059 · S	1/(1/1,11 + S/597)
	MFEFM	36.59 + 0.017 · S	0.267 + 0.000059 · S	1/(1/1,11 + S/597)
203-6	NEN	18.62 + 0.019 · S	0.102 + 0.00007 · S	1/(1/1,44 + S/705)
	BEB	18.09 + 0.019 · S	0.096 + 0.00007 · S	1/(1/1,13 + S/705)
	MCECM	29.96 + 0.019 · S	0.185 + 0.00007 · S	1/(1/1,65 + S/705)
	MFEFM	49.06 + 0.019 · S	0.414 + 0.00007 · S	1/(1/1,65 + S/705)
217-6	NEN	21.68 + 0.019 · S	0.137 + 0.000087 · S	1/(1/1,84 + S/870)
	BEB	21.93 + 0.019 · S	0.131 + 0.000087 · S	1/(1/1,43 + S/870)
	MCECM	36.46 + 0.019 · S	0.262 + 0.000087 · S	1/(1/2,11 + S/870)
	MFEFM	59.53 + 0.019 · S	0.579 + 0.000087 · S	1/(1/2,11 + S/870)
251-6	NEN	32.32 + 0.032 · S	0.271 + 0.00018 · S	1/(1/2,24 + S/1827)
	BEB	35.42 + 0.032 · S	0.276 + 0.00018 · S	1/(1/1,85 + S/1827)
	MCECM	56.48 + 0.032 · S	0.539 + 0.00018 · S	1/(1/2,45 + S/1827)
	MFEFM	101.1 + 0.032 · S	1.397 + 0.00018 · S	1/(1/2,45 + S/1827)
268-6	NEN	44.91 + 0.02 · S	0.434 + 0.00013 · S	1/(1/2,78 + S/2063)
	BEB	44.58 + 0.02 · S	0.425 + 0.00013 · S	1/(1/2,27 + S/2063)
	MCECM	73.71 + 0.02 · S	0.8 + 0.00013 · S	1/(1/3,07 + S/2063)
	MFEFM	131.4 + 0.02 · S	2.07 + 0.00013 · S	1/(1/3,07 + S/2063)
291-6	NEN	55.18 + 0.042 · S	0.634 + 0.00034 · S	1/(1/3,77 + S/3400)
	BEB	56.23 + 0.042 · S	0.624 + 0.00034 · S	1/(1/3,17 + S/3400)
	MCECM	87.66 + 0.042 · S	1.124 + 0.00034 · S	1/(1/4,09 + S/3400)
	MFEFM	176.8 + 0.042 · S	3.213 + 0.00034 · S	1/(1/4,09 + S/3400)
318-6	NEN	72.12 + 0.059 · S	0.979 + 0.0005 · S	1/(1/5,13 + S/5040)
	BEB	69.81 + 0.059 · S	0.922 + 0.0005 · S	1/(1/4,29 + S/5040)
	MCECM	121.4 + 0.059 · S	1.89 + 0.0005 · S	1/(1/5,72 + S/5040)
	MFEFM	203.7 + 0.059 · S	4.214 + 0.0005 · S	1/(1/5,72 + S/5040)
343-6	NEN	89.26 + 0.075 · S	1.394 + 0.00081 · S	1/(1/5,26 + S/8178)
	BEB	87.3 + 0.075 · S	1.322 + 0.00081 · S	1/(1/4,55 + S/8178)
	MCECM	145.8 + 0.075 · S	2.639 + 0.00081 · S	1/(1/5,62 + S/8178)
	MFEFM	261.5 + 0.075 · S	6.626 + 0.00081 · S	1/(1/5,62 + S/8178)

Size DA	Type	m kg	J kgm ²	C MNm/rad
174-6	NHN	8.79 + 0.02 · S	0.036 + 0.000065 · S	1/(1/0,55 + S/652)
	-	-	-	-
	MCHCM	15.46 + 0.02 · S	0.073 + 0.000065 · S	1/(1/0,57 + S/652)
	MFHFM	22.95 + 0.02 · S	0.139 + 0.000065 · S	1/(1/0,57 + S/652)
184-6	NHN	12.36 + 0.023 · S	0.059 + 0.000083 · S	1/(1/0,89 + S/839)
	-	-	-	-
	MCHCM	21.18 + 0.023 · S	0.074 + 0.000083 · S	1/(1/0,95 + S/839)
	MFHFM	34.65 + 0.023 · S	0.259 + 0.000083 · S	1/(1/0,95 + S/839)
203-6	NHN	16.56 + 0.027 · S	0.093 + 0.0001 · S	1/(1/1,23 + S/1049)
	-	-	-	-
	MCHCM	27.42 + 0.027 · S	0.174 + 0.0001 · S	1/(1/1,33 + S/1049)
	MFHFM	46.52 + 0.027 · S	0.403 + 0.0001 · S	1/(1/1,33 + S/1049)
217-6	NHN	18.96 + 0.03 · S	0.123 + 0.00014 · S	1/(1/1,52 + S/1413)
	-	-	-	-
	MCHCM	33.11 + 0.03 · S	0.245 + 0.00014 · S	1/(1/1,63 + S/1413)
	MFHFM	56.18 + 0.03 · S	0.562 + 0.00014 · S	1/(1/1,63 + S/1413)
251-6	NHN	29.54 + 0.042 · S	0.253 + 0.00025 · S	1/(1/2,05 + S/2505)
	-	-	-	-
	MCHCM	53 + 0.042 · S	0.516 + 0.00025 · S	1/(1/2,18 + S/2505)
	MFHFM	97.57 + 0.042 · S	1.374 + 0.00025 · S	1/(1/2,18 + S/2505)
268-6	NHN	41.38 + 0.043 · S	0.41 + 0.00028 · S	1/(1/2,52 + S/2803)
	-	-	-	-
	MCHCM	68.56 + 0.043 · S	0.765 + 0.00028 · S	1/(1/2,69 + S/2803)
	MFHFM	126.3 + 0.043 · S	2.035 + 0.00028 · S	1/(1/2,69 + S/2803)
291-6	NHN	51.32 + 0.056 · S	0.598 + 0.00046 · S	1/(1/3,48 + S/4627)
	-	-	-	-
	MCHCM	82.87 + 0.056 · S	1.08 + 0.00046 · S	1/(1/3,67 + S/4627)
	MFHFM	171.4 + 0.056 · S	3.163 + 0.00046 · S	1/(1/3,67 + S/4627)
318-6	NHN	67.86 + 0.074 · S	0.936 + 0.00065 · S	1/(1/4,81 + S/6527)
	-	-	-	-
	MCHCM	115.6 + 0.074 · S	1.832 + 0.00065 · S	1/(1/5,2 + S/6527)
	MFHFM	198 + 0.074 · S	4.157 + 0.00065 · S	1/(1/5,2 + S/6527)
343-6	NHN	84.41 + 0.091 · S	1.332 + 0.001 · S	1/(1/5,07 + S/10323)
	-	-	-	-
	MCHCM	139.3 + 0.091 · S	2.556 + 0.001 · S	1/(1/5,33 + S/10323)
	MFHFM	255 + 0.091 · S	6.542 + 0.001 · S	1/(1/5,33 + S/10323)

Variant with E spacer

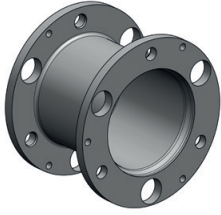

Size DA	Type	m kg	J kgm ²	C MNm/rad
219-8	NEN	28.17 + 0.027 · S	0.177 + 0.000089 · S	1/(1/3,98 + S/889)
	MCECM	44.48 + 0.027 · S	0.338 + 0.000089 · S	1/(1/6,11 + S/889)
	MFEFM	71.89 + 0.027 · S	0.703 + 0.000089 · S	1/(1/6,11 + S/889)
241-8	NEN	36.79 + 0.032 · S	0.276 + 0.00013 · S	1/(1/4,69 + S/1264)
	MCECM	61.04 + 0.032 · S	0.56 + 0.00013 · S	1/(1/6,74 + S/1264)
	MFEFM	91.45 + 0.032 · S	1.074 + 0.00013 · S	1/(1/6,74 + S/1264)
262-8	NEN	46.53 + 0.04 · S	0.414 + 0.00019 · S	1/(1/5,4 + S/1884)
	MCECM	78.23 + 0.04 · S	0.846 + 0.00019 · S	1/(1/7,22 + S/1884)
	MFEFM	120.1 + 0.04 · S	1.692 + 0.00019 · S	1/(1/7,22 + S/1884)
285-8	NEN	61.59 + 0.051 · S	0.656 + 0.00028 · S	1/(1/7,04 + S/2836)
	MCECM	100.8 + 0.051 · S	1.315 + 0.00028 · S	1/(1/9,31 + S/2836)
	MFEFM	155 + 0.051 · S	2.552 + 0.00028 · S	1/(1/9,31 + S/2836)
302-8	NEN	78.21 + 0.062 · S	0.948 + 0.00039 · S	1/(1/9,87 + S/3948)
	MCECM	122.3 + 0.062 · S	1.774 + 0.00039 · S	1/(1/13,4 + S/3948)
	MFEFM	182 + 0.062 · S	3.359 + 0.00039 · S	1/(1/13,4 + S/3948)
321-8	NEN	96.07 + 0.066 · S	1.317 + 0.0005 · S	1/(1/13,9 + S/5053)
	MCECM	150 + 0.066 · S	2.469 + 0.0005 · S	1/(1/20,1 + S/5053)
	MFEFM	216.6 + 0.066 · S	4.48 + 0.0005 · S	1/(1/20,1 + S/5053)
354-8	NEN	129.1 + 0.079 · S	2.163 + 0.00079 · S	1/(1/18,2 + S/7977)
	MCECM	191.4 + 0.079 · S	3.866 + 0.00079 · S	1/(1/24,7 + S/7977)
	MFEFM	286.5 + 0.079 · S	7.246 + 0.00079 · S	1/(1/24,7 + S/7977)
387-8	NEN	169.6 + 0.093 · S	3.414 + 0.0012 · S	1/(1/25,3 + S/11742)
	MCECM	242.5 + 0.093 · S	5.88 + 0.0012 · S	1/(1/31,5 + S/11742)
	MFEFM	351.7 + 0.093 · S	10.62 + 0.0012 · S	1/(1/31,5 + S/11742)
411-8	NEN	201.9 + 0.113 · S	4.565 + 0.0015 · S	1/(1/29,4 + S/15183)
	MCECM	287.1 + 0.113 · S	7.821 + 0.0015 · S	1/(1/36 + S/15183)
	MFEFM	415.8 + 0.113 · S	14.1 + 0.0015 · S	1/(1/36 + S/15183)
447-8	NEN	260.7 + 0.129 · S	6.985 + 0.0021 · S	1/(1/38 + S/21062)
	MCECM	367.1 + 0.129 · S	11.74 + 0.0021 · S	1/(1/46,5 + S/21062)
	MFEFM	534.1 + 0.129 · S	21.22 + 0.0021 · S	1/(1/46,5 + S/21062)
495-8	NEN	354.4 + 0.157 · S	11.61 + 0.0033 · S	1/(1/46,4 + S/33418)
	MCECM	497.5 + 0.157 · S	19.74 + 0.0033 · S	1/(1/54,5 + S/33418)
	MFEFM	693.8 + 0.157 · S	33.95 + 0.0033 · S	1/(1/54,5 + S/33418)
546-8	NEN	483.3 + 0.212 · S	19.43 + 0.0056 · S	1/(1/59 + S/56448)
	MCECM	663.8 + 0.212 · S	32.27 + 0.0056 · S	1/(1/67 + S/56448)
	MFEFM	923.1 + 0.212 · S	55.39 + 0.0056 · S	1/(1/67 + S/56448)
587-8	NEN	600.7 + 0.279 · S	27.94 + 0.0076 · S	1/(1/67,3 + S/76570)
	MCECM	821.9 + 0.279 · S	45.85 + 0.0076 · S	1/(1/75,3 + S/76570)
	MFEFM	1147 + 0.279 · S	79.25 + 0.0076 · S	1/(1/75,3 + S/76570)
631-8	NEN	731.9 + 0.302 · S	39.04 + 0.01 · S	1/(1/79,6 + S/102143)
	MCECM	1006 + 0.302 · S	64.52 + 0.01 · S	1/(1/88,2 + S/102143)
	MFEFM	1441 + 0.302 · S	114.7 + 0.01 · S	1/(1/88,2 + S/102143)

Variant with H spacer

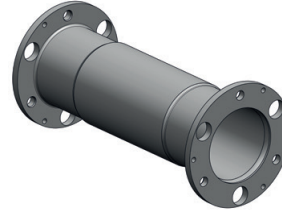

Size DA	Type	m kg	J kgm ²	C MNm/rad
219-8	NHN	26.88 + 0.035 · S	0.172 + 0.00012 · S	1/(1/3,35 + S/1176)
	MCHCM	42.52 + 0.035 · S	0.33 + 0.00012 · S	1/(1/4,3 + S/1176)
	MFHFM	69.94 + 0.035 · S	0.695 + 0.00012 · S	1/(1/4,3 + S/1176)
241-8	NHN	34.62 + 0.044 · S	0.266 + 0.00018 · S	1/(1/3,88 + S/1760)
	MCHCM	57.91 + 0.044 · S	0.546 + 0.00018 · S	1/(1/4,73 + S/1760)
	MFHFM	88.32 + 0.044 · S	1.06 + 0.00018 · S	1/(1/4,73 + S/1760)
262-8	NHN	44.21 + 0.054 · S	0.402 + 0.00025 · S	1/(1/4,72 + S/2549)
	MCHCM	74.72 + 0.054 · S	0.828 + 0.00025 · S	1/(1/5,65 + S/2549)
	MFHFM	116.5 + 0.054 · S	1.673 + 0.00025 · S	1/(1/5,65 + S/2549)
285-8	NHN	59.68 + 0.064 · S	0.643 + 0.00035 · S	1/(1/6,46 + S/3534)
	MCHCM	97.63 + 0.064 · S	1.296 + 0.00035 · S	1/(1/7,87 + S/3534)
	MFHFM	151.8 + 0.064 · S	2.533 + 0.00035 · S	1/(1/7,87 + S/3534)
302-8	NHN	75.6 + 0.078 · S	0.928 + 0.00049 · S	1/(1/8,95 + S/4945)
	MCHCM	118.1 + 0.078 · S	1.744 + 0.00049 · S	1/(1/11,1 + S/4945)
	MFHFM	177.7 + 0.078 · S	3.329 + 0.00049 · S	1/(1/11,1 + S/4945)
321-8	NHN	92.41 + 0.086 · S	1.285 + 0.00065 · S	1/(1/12,2 + S/6577)
	MCHCM	144.2 + 0.086 · S	2.419 + 0.00065 · S	1/(1/15,4 + S/6577)
	MFHFM	210.8 + 0.086 · S	4.43 + 0.00065 · S	1/(1/15,4 + S/6577)
354-8	NHN	126 + 0.098 · S	2.129 + 0.00098 · S	1/(1/16,7 + S/9874)
	MCHCM	186 + 0.098 · S	3.809 + 0.00098 · S	1/(1/20,8 + S/9874)
	MFHFM	281.2 + 0.098 · S	7.189 + 0.00098 · S	1/(1/20,8 + S/9874)
387-8	NHN	164.5 + 0.122 · S	3.343 + 0.0015 · S	1/(1/22,8 + S/15253)
	MCHCM	234.9 + 0.122 · S	5.777 + 0.0015 · S	1/(1/26,4 + S/15253)
	MFHFM	344.1 + 0.122 · S	10.51 + 0.0015 · S	1/(1/26,4 + S/15253)
411-8	NHN	196.8 + 0.141 · S	4.49 + 0.0019 · S	1/(1/27,1 + S/18813)
	MCHCM	279.5 + 0.141 · S	7.712 + 0.0019 · S	1/(1/31,3 + S/18813)
	MFHFM	408.1 + 0.141 · S	13.99 + 0.0019 · S	1/(1/31,3 + S/18813)
447-8	NHN	255.1 + 0.157 · S	6.883 + 0.0026 · S	1/(1/35,1 + S/25615)
	MCHCM	358.7 + 0.157 · S	11.59 + 0.0026 · S	1/(1/40,9 + S/25615)
	MFHFM	525.6 + 0.157 · S	21.07 + 0.0026 · S	1/(1/40,9 + S/25615)
495-8	NHN	345 + 0.2 · S	11.39 + 0.0042 · S	1/(1/43 + S/42683)
	MCHCM	483.5 + 0.2 · S	19.42 + 0.0042 · S	1/(1/48,2 + S/42683)
	MFHFM	679.8 + 0.2 · S	33.62 + 0.0042 · S	1/(1/48,2 + S/42683)
546-8	NHN	474 + 0.255 · S	19.16 + 0.0068 · S	1/(1/56,3 + S/67807)
	MCHCM	649.6 + 0.255 · S	31.86 + 0.0068 · S	1/(1/62,2 + S/67807)
	MFHFM	908.9 + 0.255 · S	54.99 + 0.0068 · S	1/(1/62,2 + S/67807)
587-8	NHN	590 + 0.324 · S	27.6 + 0.0088 · S	1/(1/65 + S/88708)
	MCHCM	806 + 0.324 · S	45.37 + 0.0088 · S	1/(1/71,2 + S/88708)
	MFHFM	1131 + 0.324 · S	78.77 + 0.0088 · S	1/(1/71,2 + S/88708)
631-8	NHN	715.1 + 0.361 · S	38.39 + 0.012 · S	1/(1/76,3 + S/123294)
	MCHCM	981.7 + 0.361 · S	63.61 + 0.012 · S	1/(1/82,6 + S/123294)
	MFHFM	1417 + 0.361 · S	113.8 + 0.012 · S	1/(1/82,6 + S/123294)

LENGTH-DEPENDENT SPECIFICATIONS

of types NEN/ NHN, BEB, MCECM/MCHCM and MFEFM/MFHFM

Variant with E spacer

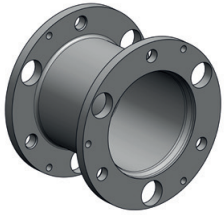

Variant with H spacer

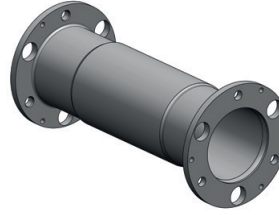

6

Size DA	Type	m kg	J kgm ²	C MNm/rad
495-10	NEN	355.1 + 0.157 · S	11.7 + 0.0033 · S	1/(1/113 + S/33418)
	MFEFM	693 + 0.157 · S	33.97 + 0.0033 · S	1/(1/176 + S/33418)
546-10	NEN	483.7 + 0.212 · S	19.56 + 0.0056 · S	1/(1/138 + S/56448)
	MFEFM	921.8 + 0.212 · S	55.43 + 0.0056 · S	1/(1/190 + S/56448)
587-10	NEN	600.5 + 0.279 · S	28.09 + 0.0076 · S	1/(1/165 + S/76570)
	MFEFM	1145 + 0.279 · S	79.29 + 0.0076 · S	1/(1/223 + S/76570)
631-10	NEN	731.3 + 0.302 · S	39.23 + 0.01 · S	1/(1/187 + S/102143)
	MFEFM	1438 + 0.302 · S	114.8 + 0.01 · S	1/(1/241 + S/102143)
694-10	NEN	1057 + 0.39 · S	69.77 + 0.015 · S	1/(1/293 + S/154224)
	MFEFM	1950 + 0.39 · S	188.1 + 0.015 · S	1/(1/412 + S/154224)
734-10	NEN	1265 + 0.45 · S	94.03 + 0.02 · S	1/(1/373 + S/196935)
	MFEFM	2314 + 0.45 · S	248.7 + 0.02 · S	1/(1/542 + S/196935)
790-10	NEN	1587 + 0.53 · S	136.9 + 0.027 · S	1/(1/467 + S/270335)
	MFEFM	2919 + 0.53 · S	363.4 + 0.027 · S	1/(1/677 + S/270335)
887-10	NEN	2335 + 0.687 · S	256 + 0.042 · S	1/(1/644 + S/418343)
	MFEFM	4197 + 0.687 · S	665.8 + 0.042 · S	1/(1/944 + S/418343)
988-10	NEN	3264 + 0.975 · S	447.8 + 0.067 · S	1/(1/856 + S/675886)
	MFEFM	5736 + 0.975 · S	1129 + 0.067 · S	1/(1/1229 + S/675886)

Size DA	Type	m kg	J kgm ²	C MNm/rad
495-10	NHN	345.7 + 0.2 · S	11.47 + 0.0042 · S	1/(1/94,7 + S/42683)
	MFHFM	678.9 + 0.2 · S	33.65 + 0.0042 · S	1/(1/124 + S/42683)
546-10	NHN	474.4 + 0.255 · S	19.28 + 0.0068 · S	1/(1/124 + S/67807)
	MFHFM	907.5 + 0.255 · S	55.03 + 0.0068 · S	1/(1/156 + S/67807)
587-10	NHN	589.9 + 0.324 · S	27.76 + 0.0088 · S	1/(1/152 + S/88708)
	MFHFM	1129 + 0.324 · S	78.81 + 0.0088 · S	1/(1/191 + S/88708)
631-10	NHN	714.5 + 0.361 · S	38.57 + 0.012 · S	1/(1/169 + S/123294)
	MFHFM	1414 + 0.361 · S	113.9 + 0.012 · S	1/(1/204 + S/123294)
694-10	NHN	1028 + 0.487 · S	68.47 + 0.019 · S	1/(1/257 + S/193881)
	MFHFM	1906 + 0.487 · S	186.2 + 0.019 · S	1/(1/322 + S/193881)
734-10	NHN	1229 + 0.563 · S	92.27 + 0.025 · S	1/(1/325 + S/247708)
	MFHFM	2260 + 0.563 · S	246.1 + 0.025 · S	1/(1/414 + S/247708)
790-10	NHN	1544 + 0.663 · S	134.4 + 0.034 · S	1/(1/409 + S/340076)
	MFHFM	2852 + 0.663 · S	359.6 + 0.034 · S	1/(1/522 + S/340076)
887-10	NHN	2278 + 0.844 · S	252 + 0.051 · S	1/(1/568 + S/517255)
	MFHFM	4107 + 0.844 · S	659.8 + 0.051 · S	1/(1/734 + S/517255)
988-10	NHN	3192 + 1.154 · S	441.8 + 0.08 · S	1/(1/774 + S/807126)
	MFHFM	5620 + 1.154 · S	1120 + 0.08 · S	1/(1/1006 + S/807126)

OTHER DESIGN OPTIONS

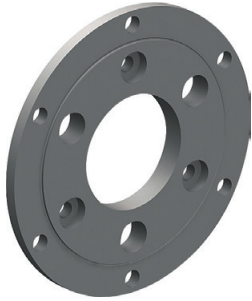

Flange version for adaptation to a customer flange



Intermediate spacer as a torsion shaft for reducing the torsional stiffness

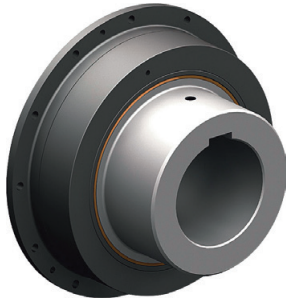

Slipping flanges for overload protection against brief high-frequency torque shock loads

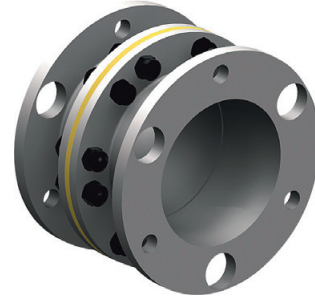

Version for avoiding leakage currents between the connected units



Slipping hubs for overload protection against brief high-frequency torque shock loads



Vertical support for avoiding excessive axial loading of the plate packs by the weight of the intermediate spacer



Axial backlash limiter



Brake disk/brake drum

GENERAL

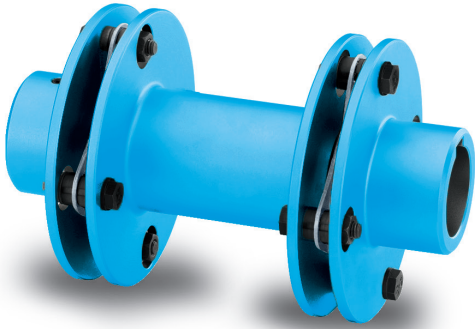

Coupling suitable for use in potentially explosive atmospheres.

Complies with the current ATEX Directive for:

CE Ex II 2G Ex h IIC T6 ... T2 Gb X

Ex II 2D Ex h IIIC T85 °C ... 250 °C Db X

Ex I M2 Ex h Mb X

6

Benefits

ARPEX couplings of the ARW-4/-6 series are outstanding for their large angular misalignment capacity of 3°. They were specially designed for drives where high misalign-

ments which have to be compensated for by the coupling are to be expected. The intermediate spacer lengths are variable and are manufactured to customer specifications.

Application

ARPEX couplings of the ARW-4/-6 series are used where large misalignment capacities are required. In the paper-making machine industry, the ARW coupling has already proved itself as a maintenance-free alternative to the cardan shaft. Torques of between 92 and 80000 Nm can be transmitted at a permitted angular misalignment of 3.0°. The intermediate spacer can be fitted radially without moving the connected units.

Main areas of application for the ARW-4/-6 series:

- Paper-making machines
- Wind power systems
- Traction drives

Design and configurations

The design of an ARPEX NHN coupling of the ARW-4/-6 series is shown in the following illustration. The plate packs are bolted alternately between the flanges of the coupling hubs and the intermediate spacer. Up to size 292-4 close-fitting bolts and from size 324-4 conical screw connections are used for fastening.

Up to size 647-4 plate packs in rectangular design, from size 695-6 in hexagonal design are used. The intermediate spacers are variable in length and are manufactured specifically to customer specifications.

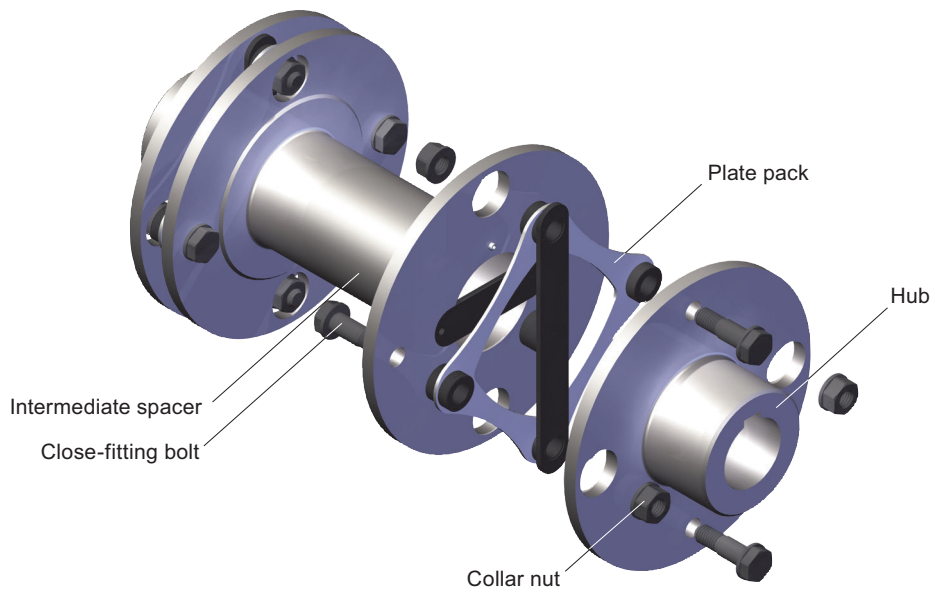

Variants of the ARPEX coupling, ARW-4/-6 series

G_MD10_EN_00163a

Variants of the ARPEX coupling, ARW-4/-6 series

Type	Description
NHN	Variant with unmachined intermediate spacer, with variable spacer length

The article number can be obtained with the help of the Configurator. The coupling can be selected in a product configurator and specified using selection menus.

The Configurator is available under flender.com

The coupling can be selected via "Technical selection" (technical selection) or via "Direct selection" (via article-no.).

The coupling parts of the ARPEX ARW-4/-6 series with the exception of H spacers are machined on all sides. These are delivered with unmachined, primed spacer tube.

GENERAL

Technical specifications

Power ratings											
Size	Rated torque T_{KN}	Maximum torque T_{Kmax}	Overload torque $T_{KO/L}$	Fatigue torque T_{KW}	Maximum speed n_{Kmax}	Maximum permitted shaft misalignment				Torsional stiffness C_{Tdyn}	
						+ ΔK_a Tension mm	- ΔK_a Compression mm	$\pm \Delta K_w$	$\pm \Delta K_r$ mm		MNm/rad
	Nm	Nm	Nm	Nm	rpm					for S = 1000 mm	for S = 1000 mm
101-4	92	140	230	37	10400	2.4	2			51.8	0.006
133-4	225	340	560	90	7850	3.3	2.2			51.7	0.012
167-4	450	680	1130	180	6250	4.2	2.2			51.6	0.028
196-4	800	1200	2000	320	5350	5.1	2.2			51.6	0.068
230-4	1250	1880	3200	500	4550	5.7	2.2			51.6	0.108
260-4	2000	3000	5000	800	4000	6.6	2.2			51.5	0.174
292-4	2700	4100	6800	1080	3550	7.5	2.8			51.4	0.275
324-4	3850	5800	9700	1540	3200	8.4	2.8			51.4	0.451
355-4	5250	7900	13200	2100	2950	9	2.8			51.4	0.622
389-4	6650	10000	16700	2660	2700	10	2.8	3.0 °		51.4	0.657
439-4	9850	15000	25000	3940	2350	11.1	3			51.3	1.08
499-4	13300	20000	34000	5320	2100	12.4	4.8			50.8	1.32
547-4	19000	29000	48000	7600	1900	13.4	4.8			50.7	2.03
600-4	25150	38000	63000	10060	1750	14.6	4.8			50.6	2.73
647-4	32500	49000	82000	13000	1600	16	4.8			50.6	3.93
695-6	41000	62000	103000	16400	1500	17	4.8			50.7	10.1
756-6	52000	78000	130000	20800	1350	18	4.8			50.6	14
817-6	65000	98000	163000	26000	1250	20	4.8			50.5	16.9
880-6	80000	120000	200000	32000	1150	22	4.8			50.5	21.2

The radial misalignment ΔK_r applies to a type NHN coupling with a shaft distance $S = 1000$ mm. The radial misalignment ΔK_r for other shaft distances S is calculated as follows: $\Delta K_r = (S - S1) \cdot \tan(\Delta K_w)$

The permitted shaft misalignments ΔK_a , ΔK_r and ΔK_w are maximum values and must not occur at the same time (see following table).

The torsional stiffness values apply to the entire coupling with shaft distance $S = 1000$ mm. The torsional stiffness of the plate packs applies to the rated coupling torque T_{KN} . To determine the torsional stiffness for a specific operating point, e.g. for calculating torsional vibration, the manufacturer must be consulted.

- T_{Kmax} permitted only five times per hour.
- T_{KW} for medium torque $T_N = 0$ Nm.
- If T_N and T_{KW} occur at the same time, the manufacturer must be consulted.

Permitted shaft misalignments						
Size	Permitted angular misalignment ΔK_w (tension +)			Permitted angular misalignment ΔK_w (compression -)		
	3.0 °	1.5 °	0.0 °	3.0 °	1.5 °	0.0 °
	Permitted axial misalignment ΔK_a in mm			Permitted axial misalignment ΔK_a in mm		
101-4	0.8	1.6	2.4	0.8	1.6	2
133-4	1.1	2.2	3.3	1.1	2.2	2.2
167-4	1.4	2.8	4.2	1.4	2.2	2.2
196-4	1.7	3.4	5.1	1.7	2.2	2.2
230-4	1.9	3.8	5.7	1.9	2.2	2.2
260-4	2.2	4.4	6.6	2.2	2.2	2.2
292-4	2.5	5	7.5	2.5	2.8	2.8
324-4	2.8	5.6	8.4	2.8	2.8	2.8
355-4	3	6	9	2.8	2.8	2.8
389-4	3.3	6.7	10	2.8	2.8	2.8
439-4	3.7	7.4	11.1	3	3	3
499-4	4.1	8.3	12.4	4.1	4.8	4.8
547-4	4.5	8.9	13.4	4.4	4.8	4.8
600-4	4.9	9.7	14.6	4.8	4.8	4.8
647-4	5.3	10.7	16	4.8	4.8	4.8
695-6	5.6	11.4	17	4.8	4.8	4.8
756-6	6	12.1	18	4.8	4.8	4.8
817-6	6.7	13.4	20	4.8	4.8	4.8
880-6	7.3	14.8	22	4.8	4.8	4.8

Because of design specifications, the maximum possible axial shaft misalignment with plate packs pulled apart (**tension +**) is greater than with plate packs pressed together (**compression -**).

TYPE NHN

Torsionally rigid type NHN coupling with high angular misalignment capacity up to 3° and radially freely dismountable intermediate spacer and variable shaft distance S.

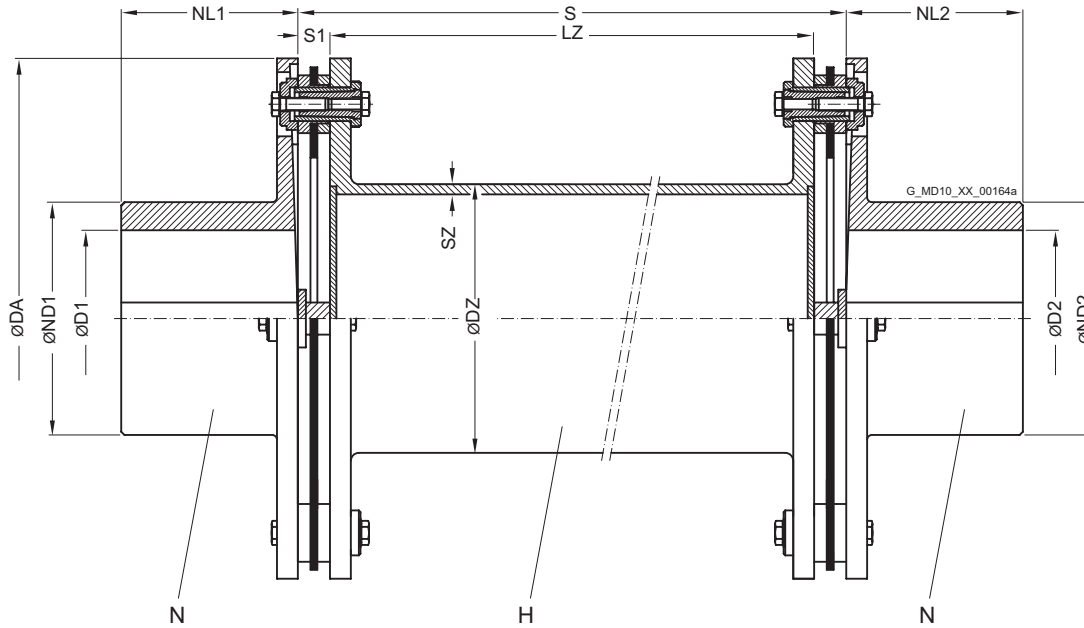

Size	Rated torque	Maximum speed	Dimensions in mm								Mass moment of inertia	Article no. ¹⁾	Weight
DA	T_{KN}	n_{Kmax}	D1, D2 Keyway DIN 6885 max.	ND1/ND2	DZ	SZ	NL1/NL2	S1	LZ	Shaft distance S	J		m
mm	Nm	rpm									kgm ²		kg
101-4	92	10400	32	45	45	2.9	32	11	43	65	0.002	2LC0530-0AD	1.5
133-4	225	7850	45	60	48	2.9	45	13	59	85	0.008	2LC0530-1AD	3.9
167-4	450	6250	50	70	64	4	50	15	70	100	0.022	2LC0530-2AD	7.1
196-4	800	5350	60	80	89	4	60	16	83	115	0.056	2LC0530-3AD	12.1
230-4	1250	4550	75	100	102	5	75	16	83	115	0.109	2LC0530-4AD	17.9
260-4	2000	4000	90	120	133	5	90	17	96	130	0.189	2LC0530-5AD	24.6
292-4	2700	3550	100	130	152	5	100	19	92	130	0.359	2LC0530-6AD	35.1
324-4	3850	3200	110	145	168	6.3	110	20	120	160	0.52	2LC0530-7AD	43.7
355-4	5250	2950	120	160	178	7.1	120	20	125	165	0.856	2LC0530-8AD	59.8
389-4	6650	2700	130	175	194	7.1	130	20	130	170	1.09	2LC0531-0AD	68.9
439-4	9850	2350	150	200	219	7.1	150	22	166	210	2.23	2LC0531-1AD	106
499-4	13300	2100	165	220	245	7.1	165	30	170	230	3.81	2LC0531-2AD	142
547-4	19000	1900	190	250	299	8.8	190	32	176	240	6.24	2LC0531-3AD	191
600-4	25150	1750	205	275	324	8.8	205	34	182	250	10.2	2LC0531-4AD	257
647-4	32500	1600	225	300	343	10	225	35	220	290	16.5	2LC0531-5AD	348
695-6	41000	1500	240	325	368	10	240	33	224	290	23.7	2LC0540-0AD	441
756-6	52000	1350	255	340	394	12.5	255	34	232	300	33.2	2LC0540-1AD	525
817-6	65000	1250	270	360	406	12.5	270	36	238	310	49.1	2LC0540-2AD	659
880-6	80000	1150	300	400	419	12.5	300	37	256	330	72.8	2LC0540-3AD	849

Configurable variants ¹⁾

- ØD1 Without finished bore
With finished bore
- ØD2 Without finished bore
With finished bore

¹⁾ To identify complete item numbers specifying the available finish boring options and – if necessary – further order options, please use our configurators on flender.com.

➤ For online configuration on flender.com, click on the item no.

Permitted shaft distance S of type NHN relative to speed													
Size DA mm	Speed n_N												
	500 rpm	600	700	800	900	1000	1200	1400	1500	2000	2500	3000	4000
Permitted shaft distance S in mm													
101-4	2822	2577	2387	2233	2106	1999	1825	1691	1634	1416	1268	1159	1005
133-4	2949	2693	2494	2334	2201	2089	1908	1767	1708	1481	1326	1212	1051
167-4	3376	3083	2856	2672	2520	2392	2185	2024	1956	1696	1518	1387	1203
196-4	4029	3679	3407	3188	3007	2854	2606	2414	2333	2022	1811	1654	1435
230-4	4297	3924	3634	3400	3207	3043	2779	2574	2488	2156	1930	1764	1530
260-4	4943	4514	4181	3912	3689	3500	3197	2961	2861	2480	2220	2028	1759
292-4	5305	4844	4487	4198	3959	3757	3431	3178	3071	2662	2383	2177	
324-4	5562	5079	4704	4401	4151	3939	3597	3332	3220	2791	2499	2283	
355-4	5709	5214	4828	4518	4261	4043	3692	3420	3305	2865	2564		
389-4	5968	5450	5047	4722	4453	4226	3859	3575	3454	2994	2680		
439-4	6361	5809	5380	5034	4747	4505	4114	3811	3682	3192			
499-4	6738	6154	5699	5333	5030	4773	4360	4039	3903	3384			
547-4	7442	6797	6295	5890	5555	5272	4815	4460	4310				
600-4	7762	7089	6565	6144	5794	5499	5022	4652	4496				
647-4	7980	7287	6750	6316	5957	5653	5163	4783	4622				
695-6	8000	7553	6995	6545	6173	5858	5350	4956	4789				
756-6	8000	7797	7221	6757	6372	6047	5523						
817-6	8000	7920	7335	6864	6473	6143	5611						
880-6	8000	8000	7456	6977	6580	6244							

Outside the permitted speed range

Notes

- The permitted length of the intermediate spacer depends on the maximum operating speed of the coupling. In the case of individual order of the intermediate spacer, the length [LZ] must be specified.
- Mass moments of inertia and weights apply to the entire NHN coupling with maximum bores D1/D2 and a shaft distance S = S min.

Ordering example

- ARPEX ARW-4 NHN coupling, size 133-4, with shaft distance S = 1000 mm,
- Bore ØD1 40H7 mm, with keyway to DIN 6885 and set screw
- Bore ØD2 45K7 mm, with keyway to DIN 6885 and set screw

Article no.: 2LC0530-1AD99-0AZ0-Z L0W+M1A+Q0Y+M13
Plain text to Q0Y: S = 1000 mm

¹⁾ To identify complete item numbers specifying the available finish boring options and – if necessary – further order options, please use our configurators on flender.com.
↗ For online configuration on flender.com, click on the item no.

SPARE AND WEAR PARTS

Plate pack, ARW-4/-6 series

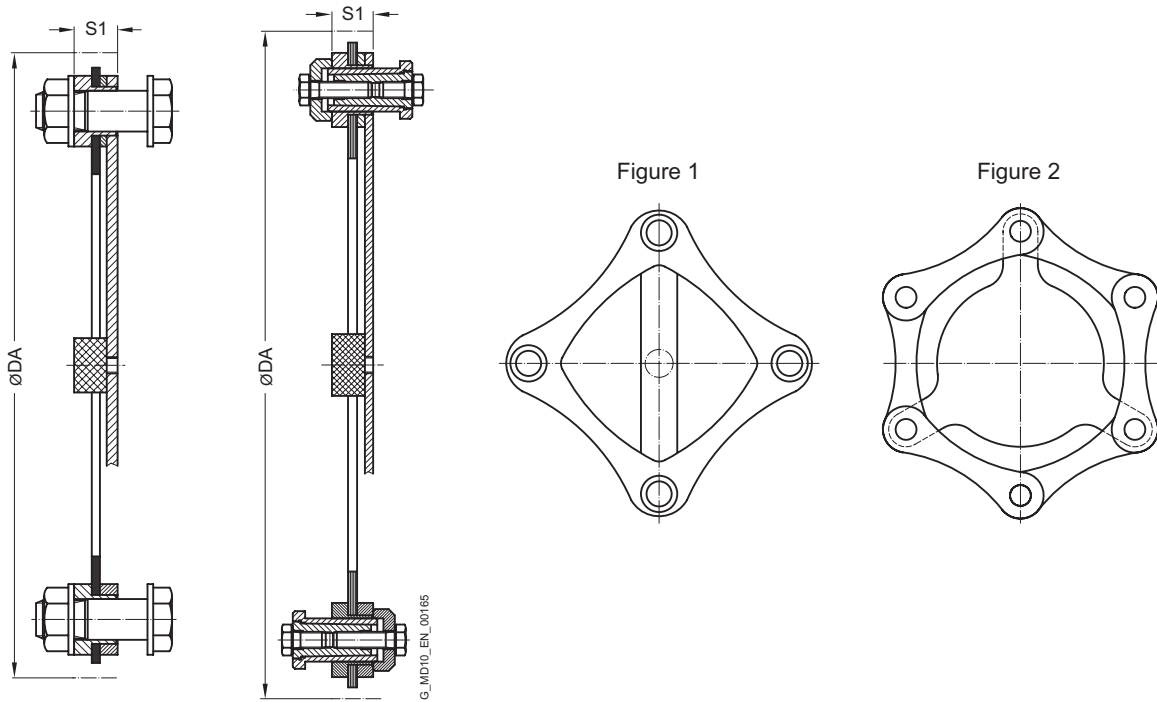

Size DA mm	Dimensions S1 mm	Mass moment of inertia J kgm ²	Article No.	Weight m kg
101-4	11	0.0001	2LC0530-0AB00-0AA0	0.1
133-4	13	0.0005	2LC0530-1AB00-0AA0	0.2
167-4	15	0.0017	2LC0530-2AB00-0AA0	0.5
196-4	16	0.0037	2LC0530-3AB00-0AA0	0.7
230-4	16	0.0068	2LC0530-4AB00-0AA0	1
260-4	17	0.0136	2LC0530-5AB00-0AA0	1.5
292-4	19	0.0227	2LC0530-6AB00-0AA0	1.9
324-4	20	0.0288	2LC0530-7AB00-0AA0	2.1
355-4	20	0.0452	2LC0530-8AB00-0AA0	2.7
389-4	20	0.0645	2LC0531-0AB00-0AA0	3.2
439-4	22	0.1147	2LC0531-1AB00-0AA0	4.5
499-4	30	0.2235	2LC0531-2AB00-0AA0	6.9
547-4	32	0.3658	2LC0531-3AB00-0AA0	9.5
600-4	34	0.5355	2LC0531-4AB00-0AA0	11.4
647-4	35	0.7939	2LC0531-5AB00-0AA0	14.6
695-6	33	1.4624	2LC0540-0AB00-0AA0	24.6
756-6	34	1.225	2LC0540-1AB00-0AA0	20.2
817-6	36	1.7497	2LC0540-2AB00-0AA0	23.9
880-6	37	2.546	2LC0540-3AB00-0AA0	28.9

Notes

- Plate packs of the ARW-4 series comprise ring plates (Fig. 1), those of the ARW-6 series side-bar plates (Fig. 2).
- The plate pack of the ARW-4/-6 series is readily available as a spare part.
- The plate pack is delivered with screw connection.
- Up to size 292-4 close-fitting bolts with collar nuts, from size 324-4 conical screw connections are used.

Ordering example

- ARPEX ARW-4 plate pack, size 133-4, complete with screw connection.

Article no.: 2LC0530-1AB00-0AA0

GENERAL



Coupling suitable for use in potentially explosive atmospheres.

Complies with the current ATEX Directive for:

CE  II 2G Ex h IIC T6 ... T2 Gb X

 II 2D Ex h IIIC T85 °C ... 250 °C Db X

 I M2 Ex h Mb X

Benefits

ARPEX couplings of the ARF-6 series are extremely short and so suitable for drives with short shaft distances. They also serve as self-aligning couplings for axial, angular and radial misalignment. The hubs are available both as pure clamping hubs for smooth shafts and with parallel keyway

for shafts with parallel key.

The variant with slit clamping hubs enables the delivery of fully preassembled couplings. This means that the entire coupling can be dismantled and fitted without moving the connected units.

Application

ARPEX couplings of the ARF-6 series are designed for minimum fitting spaces without having to sacrifice the advantages of the two-joint coupling. It is thus possible to compensate for both axial and angular as well as radial misalignment. By using half-shell clamping hubs, the coupling can be radially freely dismantled. Power is transmitted via hexagon socket head cap screws and close-fitting bolts with nuts and ring plate packs in hexagonal design. Torques of between 120 and 6100 Nm can be transmitted at a permitted angular misalignment of 0.7°.

Main areas of application for the ARF-6 series:

- Film stretching machines
- Machines in the cellulose industry
- Machines in confined fitting situations

GENERAL

Design and configurations

The two plate packs form a unit with the adapter disk and are screwed together with close-fitting bolts and nuts at three points. The alternate connection of this intermediate unit with the flanges of the split coupling hubs is achieved by means of short hexagon socket head cap screws at further three points. The hubs are designed as axially slit

clamping hubs with a half-shell. For larger bores these can be manufactured as jumbo hubs. Optionally, the hubs are also available without parallel keyway.

6

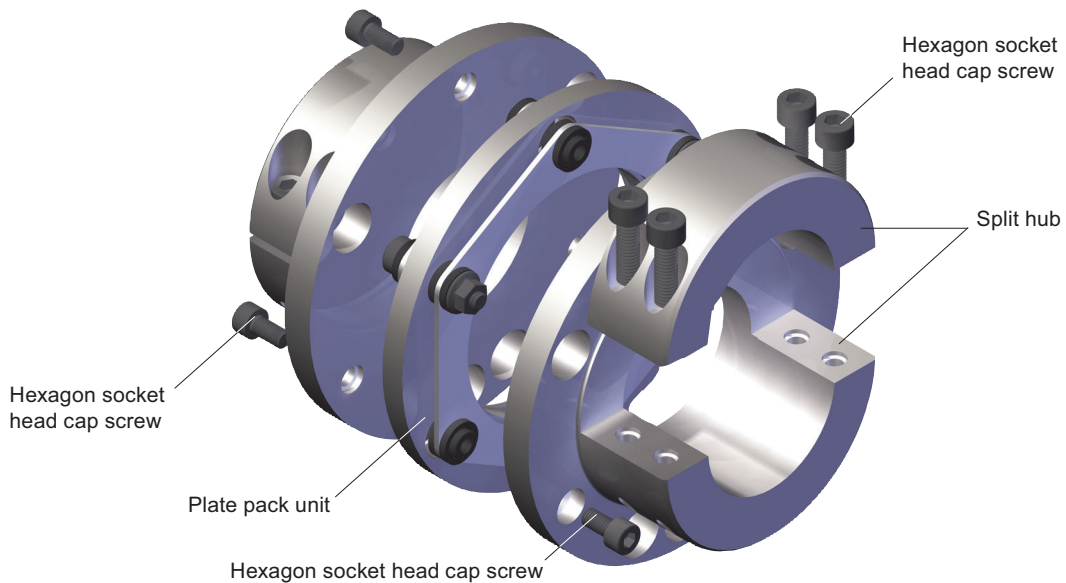

G_MD10_EN_0016

Design of the ARPEX coupling, ARF series

Variants of the ARF coupling

Type	Description
GG	Variant with 2 standard clamping hubs
GJ	Variant with 1 jumbo clamping hub for large bore diameters

The article number can be obtained with the help of the Configurator. The coupling can be selected in a product configurator and specified using selection menus.

The Configurator is available under flender.com

The coupling can be selected via "Technical selection" (technical selection) or via "Direct selection" (via article-no.).

Technical specifications

Power ratings, types GG and GJ									
Size	Rated torque	Maximum torque	Overload torque	Fatigue torque	Maximum speed	Maximum permitted shaft misalignment			Torsional stiffness
	T_{KN} Nm	T_{Kmax} Nm	T_{KOL} Nm	T_{KW} Nm	n_{Kmax} rpm	$\pm\Delta K_a$ mm	$\pm\Delta K_w$	$\pm\Delta K_r$ mm	C_T MNm/rad
84-6	120	220	330	55	12500	1.1	0.7 °	0.16	0.07
111-6	190	350	520	90	9450	1.8		0.16	0.13
132-6	350	650	950	160	7950	2.02		0.2	0.2
147-6	500	900	1350	230	7100	2.4		0.2	0.28
171-6	900	1700	2450	400	6100	2.74		0.24	0.57
182-6	1450	2600	4000	650	5750	2.86		0.29	0.66
202-6	2150	3900	5800	980	5200	3.06		0.29	0.77
218-6	3200	5800	8700	1450	4800	3.14		0.37	1.25
252-6	4500	8100	12000	2000	4150	3.7		0.45	1.55
267-6	6100	11000	16500	2800	3900	3.84		0.46	1.8

The permitted shaft misalignments ΔK_a , ΔK_r and ΔK_w are maximum values and must not occur at the same time (see following table).

- T_{Kmax} permitted only five times per hour.
- T_{KW} for medium torque $T_N = 0$ Nm.
- If T_N and T_{KW} occur at the same time, the manufacturer must be consulted.

The values for torsional stiffness apply to the complete coupling. The torsional stiffness of the plate packs applies to the rated coupling torque T_{KN} . To determine the torsional stiffness for a specific operating point, e.g. for calculating torsional vibration, the manufacturer must be consulted.

Permitted shaft misalignments									
Size	Permitted angular misalignment $\pm\Delta K_w$								
	0.0 °	0.1 °	0.2 °	0.3 °	0.4 °	0.5 °	0.6 °	0.7 °	
	Permitted axial misalignment $\pm\Delta K_a$ in mm								
84-6	1.1	0.94	0.79	0.63	0.47	0.31	0.16	0	
111-6	1.8	1.54	1.29	1.03	0.77	0.51	0.26	0	
132-6	2.02	1.73	1.44	1.15	0.87	0.58	0.29	0	
147-6	2.4	2.06	1.71	1.37	1.03	0.69	0.34	0	
171-6	2.74	2.35	1.96	1.57	1.17	0.78	0.39	0	
182-6	2.86	2.45	2.04	1.63	1.23	0.82	0.41	0	
202-6	3.06	2.62	2.19	1.75	1.31	0.87	0.44	0	
218-6	3.14	2.69	2.24	1.79	1.35	0.9	0.45	0	
252-6	3.7	3.17	2.64	2.11	1.59	1.06	0.53	0	
267-6	3.84	3.29	2.74	2.19	1.65	1.1	0.55	0	

TYPES GG AND GJ

Radially freely dismountable, torsionally rigid coupling, available as types GG and GJ.

Complete dismounting without moving the units with extremely short shaft distances.

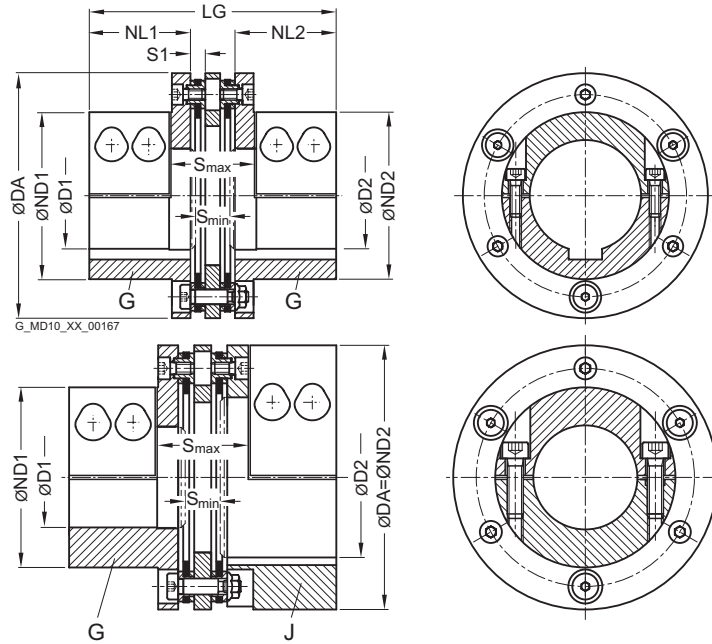

Size	Rated torque	Maximum speed	Type	Dimensions in mm										Mass moment of inertia J	Article no. ¹⁾	Weight
				DA	T _{KN}	n _{Kmax}	Keyway DIN 6885			ND1	ND2	NL1/NL2	S1			
mm	Nm	rpm		D1 max.	D2 max.	Clamping seat					min	max.	kgm ²		kg	
84-6	120	12500	GG	25	25	25	50	50	40	6	16	39	99	0.0013	2LC0420-0AB99-0AA0	1.7
			GJ	40	48	48	84	84	40	6	16	39	99	0.0021	2LC0420-0AC99-0AA0	2.1
111-6	190	9450	GG	48	48	48	76	76	40	6	16	39	99	0.0043	2LC0420-1AB99-0AA0	2.9
			GJ	65	65	65	111	111	40	6	16	39	99	0.0067	2LC0420-1AC99-0AA0	3.6
132-6	350	7950	GG	52	52	52	90	90	55	8	18.5	45	134	0.011	2LC0420-2AB99-0AA0	5.7
			GJ	75	80	80	132	132	55	8	18.5	45	134	0.0177	2LC0420-2AC99-0AA0	7
147-6	500	7100	GG	60	60	60	105	105	65	8	18.5	45	154	0.0199	2LC0420-3AB99-0AA0	8.3
			GJ	85	85	85	147	147	65	8	18.5	45	154	0.0324	2LC0420-3AC99-0AA0	10.4
171-6	900	6100	GG	70	70	70	122	122	75	9	22.5	56	179	0.0439	2LC0420-4AB99-0AA0	13.3
			GJ	100	100	100	171	171	75	9	22.5	56	179	0.0695	2LC0420-4AC99-0AA0	16.4
182-6	1450	5750	GG	70	70	70	126	126	85	11	29	71	205	0.0649	2LC0420-5AB99-0AA0	17.5
			GJ	100	110	110	182	182	85	11	29	71	205	0.1005	2LC0420-5AC99-0AA0	20.9
202-6	2150	5200	GG	75	75	75	138	138	85	11	29	71	205	0.0986	2LC0420-6AB99-0AA0	21.9
			GJ	115	125	125	202	202	85	11	29	71	205	0.1519	2LC0420-6AC99-0AA0	25.6
218-6	3200	4800	GG	90	90	90	149	149	95	14	35	86	234	0.1499	2LC0420-7AB99-0AA0	27.2
			GJ	130	130	130	218	218	95	14	35	86	234	0.2345	2LC0420-7AC99-0AA0	33.6
252-6	4500	4150	GG	100	100	100	166	166	105	17	40.5	101	264	0.2924	2LC0420-8AB99-0AA0	39.9
			GJ	140	150	150	252	252	105	17	40.5	101	264	0.4651	2LC0420-8AC99-0AA0	49.8
267-6	6100	3900	GG	110	100	100	177	177	110	17	40.5	102	275	0.3827	2LC0421-0AB99-0AA0	45.9
			GJ	150	160	160	267	267	110	17	40.5	102	275	0.6129	2LC0421-0AC99-0AA0	58.1

¹⁾ To identify complete item numbers specifying the available finish boring options and – if necessary – further order options, please use our configurators on flender.com.

↗ For online configuration on flender.com, click on the item no.

Notes

- The shaft tolerance must be specified in the order.
To specify, "-Z" must be added to the article no. and the order codes "Y26" and "Y27" with plain text specification of the shaft tolerance for D1 and D2 must be added as well.
 - Jumbo hubs for larger shaft diameters.
G and J hubs in split clamping hub variant.
The hub variant with keyway rates as standard. Optionally, the shaft/hub connection can be implemented without keyway as a pure clamping seat.
For specification of plate pack, see **Page 6/40**.
 - Weights and mass moments of inertia apply to the entire coupling with maximum bores D1/D2.
-

Ordering example

- ARPEX ARF-6 GG coupling, size 132-6
 - for shaft diameter $\varnothing D1$ 45h6 mm, without keyway
 - for shaft diameter $\varnothing D2$ 50k6 mm,
with keyway to DIN 6885-1, keyway width P9.
-

Article no.: 2LC0420-2AB99-0AA0-Z L1A+M1C+L45+Y26+Y27

Plain text to Y26: h6

Plain text to Y27: k6

¹⁾ To identify complete item numbers specifying the available finish boring options and – if necessary – further order options, please use our configurators on [flender.com](https://www.flender.com).

➤ For online configuration on [flender.com](https://www.flender.com), click on the item no.

SPARE AND WEAR PARTS

Plate pack, ARF-6 series

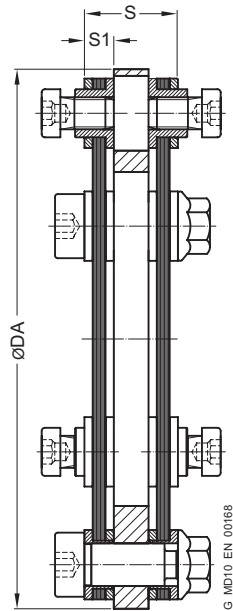
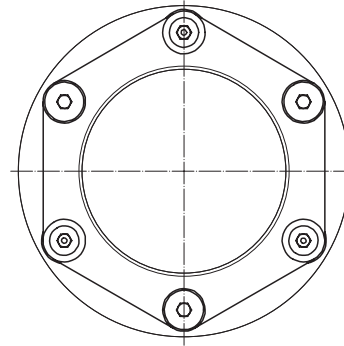

Figure 1



6

Size DA mm	Type	Dimensions S mm	S1 mm	Mass moment of inertia J kgm ²	Article No.	Weight m kg
84-6	GG	19	6	0.0003	2LC0420-0AE00-0AA0	0.3
	GJ				2LC0420-0AH00-0AA0	
111-6	GG	19	6	0.0009	2LC0420-1AE00-0AA0	0.46
	GJ				2LC0420-1AH00-0AA0	
132-6	GG	24	8	0.0026	2LC0420-2AE00-0AA0	0.9
	GJ				2LC0420-2AH00-0AA0	
147-6	GG	24	8	0.0038	2LC0420-3AE00-0AA0	1.07
	GJ				2LC0420-3AH00-0AA0	
171-6	GG	29	9	0.0097	2LC0420-4AE00-0AA0	1.96
	GJ				2LC0420-4AH00-0AA0	
182-6	GG	35	11	0.0143	2LC0420-5AE00-0AA0	2.58
	GJ				2LC0420-5AH00-0AA0	
202-6	GG	35	11	0.024	2LC0420-6AE00-0AA0	3.53
	GJ				2LC0420-6AH00-0AA0	
218-6	GG	44	14	0.0383	2LC0420-7AE00-0AA0	4.89
	GJ				2LC0420-7AH00-0AA0	
252-6	GG	54	17	0.0812	2LC0420-8AE00-0AA0	7.9
	GJ				2LC0420-8AH00-0AA0	
267-6	GG	55	17	0.1152	2LC0421-0AE00-0AA0	9.6
	GJ				2LC0421-0AH00-0AA0	

Note

- Ring plates (Figure 1) are used for the plate packs.
- The plate pack unit for the ARF-6 series is readily available as a spare part in most sizes.
- The plate pack unit comprises two preassembled plate packs with adapter disk, including screw connection. The standard screw connection comprises hexagon socket head cap screws and close-fitting bolts with nuts.